

CE

EN

English

FLAIL MOWER MP

USER AND MAINTENANCE MANUAL

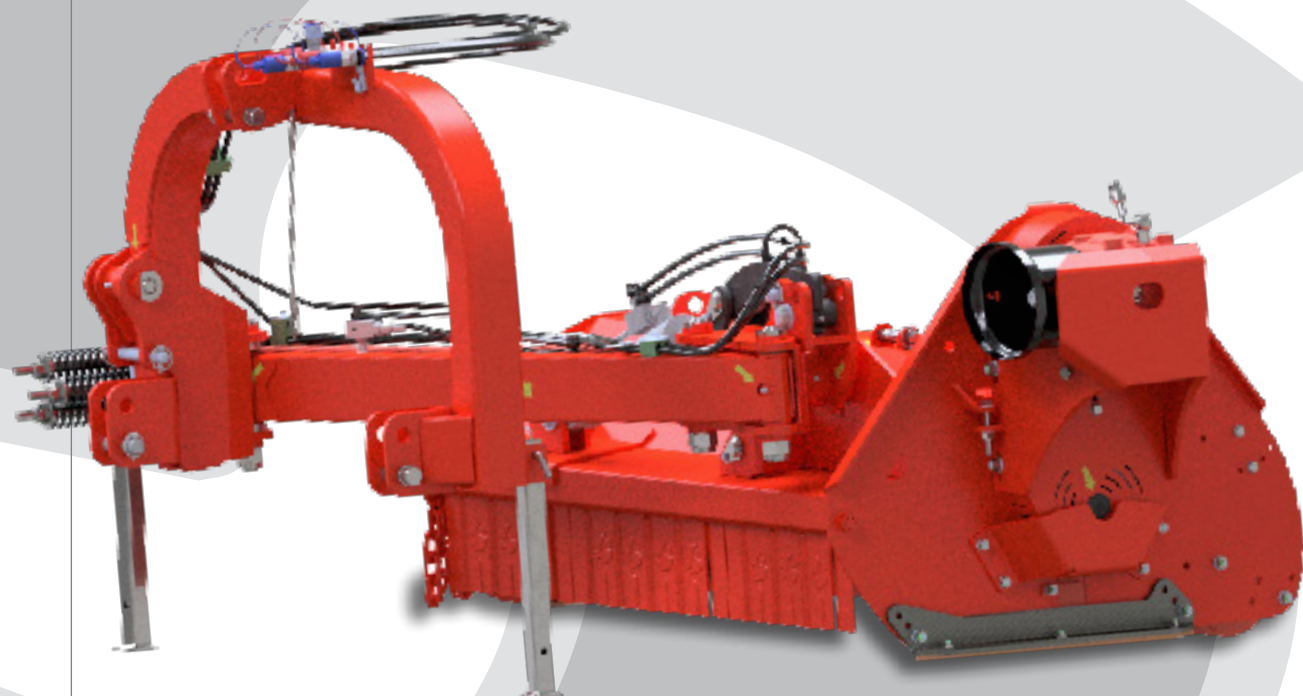

SICMA[®]

TRANSLATED INSTRUCTIONS
903685043~00

**AURORA**
GROUP
FULL MADE IN ITALY

TABLE OF CONTENTS

Para.	Title	P.
1.	FOREWORD	5
2.	GENERAL DESCRIPTION OF THE MACHINE	6
2.1	FLAIL MOWER COMPOSITION	7
3.	GENERAL SAFETY PRESCRIPTIONS	8
4.	IDENTIFICATION OF THE MACHINE	9
4.1	IDENTIFICATION PLATE	9
4.2	IDENTIFICATION CODES	10
4.3	CHECKING OF MACHINE UPON DELIVERY	10
4.4	TECHNICAL DATA	11
5.	SAFETY STANDARDS: STICKERS AND WARNINGS	12
5.1	DESCRIPTION OF STICKERS	13
6.	UNLOADING AND UNPACKING	14
7.	MACHINE INSTALLATION	15
7.1	APPLICATION TO THE TRACTOR	15
7.2	TRANSPORTING THE FLAIL MOWER	16
7.3	SPECIAL PRODUCTIONS ON THE TRACTOR	17
7.4	ADAPTING THE CARDAN SHAFT	18
8.	RULES FOR USING THE FLAIL MOWER	19
8.1	POSITION OF THE MACHINE WITH RESPECT TO THE GROUND	20
8.1	LEVEL ROLLER ADJUSTMENT	20
8.1.0	INTEGRATED SAFETY SYSTEM WITH HINGE	21
8.1.1	ADDITIONAL DIVERTER	21
8.1.2	ADJUSTING THE SKIDS	22
8.1.3	ADJUSTING THE THIRD ARM	22
8.1.4	MACHINE WORK POSITIONS	23
8.1.5	STARTING WORK	23
9.	ROUTINE MAINTENANCE	24
9.1	ADJUSTING THE BELTS AND REPLACEMENT	25
9.2	REPLACING THE KNIVES OR HAMMERS	26
9.3	TABLE OF TIGHTENING TORQUES	27
9.4	SPECIAL ACCESSORIES: - OPENABLE HOOD	27
9.5	LUBRICANTS TABLE	28
10.	PROBLEMS AND SOLUTIONS	28
11.	PUTTING THE FLAIL MOWER INTO REST MODE	29
12.	DISMANTLING	29
13.	TECHNICAL ASSISTANCE	29
14.	WARRANTY	29
14.1	WARRANTY EXPIRY	30





ATTENTION!
IT IS FORBIDDEN TO USE THE FLAIL MOWER
WITHOUT
HAVING CONSULTED THE USE AND
MAINTENANCE MANUAL

Read this manual carefully; in case of difficulty in learning, do not use the machine and for further information ask your authorised dealer or the manufacturer for information.

1. FOREWORD

This manual is an integral part of the product and must be stored properly allowing, at any time, easy consultation by the operator. It is advisable to make a copy of this manual.

The "DECLARATION OF CONFORMITY" is annexed to this manual, which certifies compliance with the relevant regulations in force and which must be shown to anyone who expressly requests it.

Furthermore, this declaration shows the "SERIAL NUMBER" of the machine. Upon delivery, check the correspondence of the serial number of the machine.

If the numbers do not match, contact the retailer immediately for the necessary checks.

"Sicma" congratulates you on your excellent choice.

During the work phases you will be able to see the qualities of use and sturdiness of your machine.

In order to maximise the qualities of this machine, it is advisable to devote some of your precious time to reading this manual. Optimum knowledge of the machine will repay you widely in terms of duration, safety and quality in productive use.

In case of uncertainty, please contact your authorised dealer, who will advise you and provide you with correct assistance as soon as possible.

Your "FLAIL MOWER" was designed exclusively to be used in agriculture. Any other use of the machine is to be considered abusive and is at the user's risk. In this case the right to warranty ceases.

Appropriate use also means compliance with the service and maintenance instructions prescribed by the manufacturer.

Only persons who are authorised and knowledgeable about possible risks must use, repair and perform maintenance on the machine.

The relevant provisions for accident prevention must be observed, as well as all other general technical provisions and the road traffic regulations for safety and hygiene.

Never make any modifications to the machine on your own initiative. Otherwise the company declines all responsibility for any damage caused to persons or property. In this case, too, the right to warranty lapses with immediate effect.

"Sicma" reserves the right to suspend the production of some models at any time to vary their characteristics and design without any commitment to give notice or to apply such changes to the models already produced.

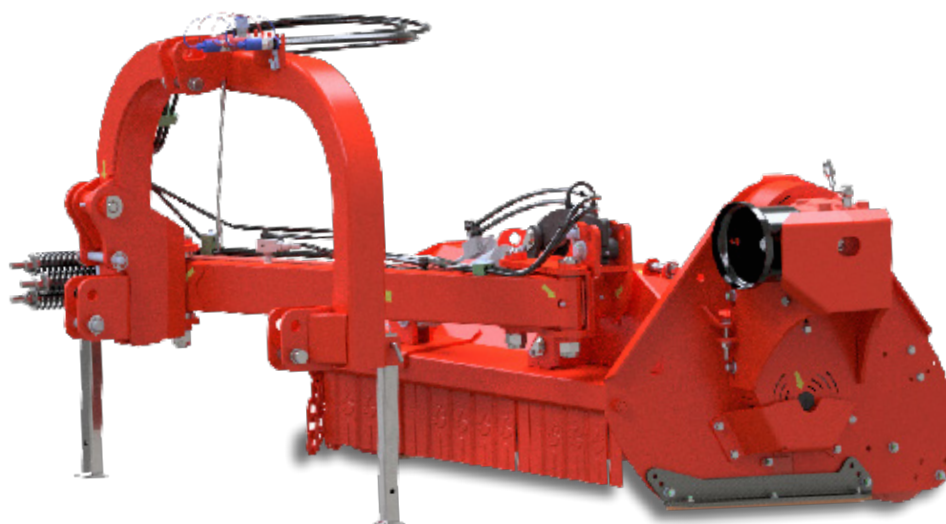

2. GENERAL DESCRIPTION OF THE MACHINE

CAUTION!

If the flail mower is delivered packaged, the packaging elements must not be left lying around as they are potential sources of danger. Place the aforementioned in the appropriate collection places if they are contaminating and/or biodegradable.

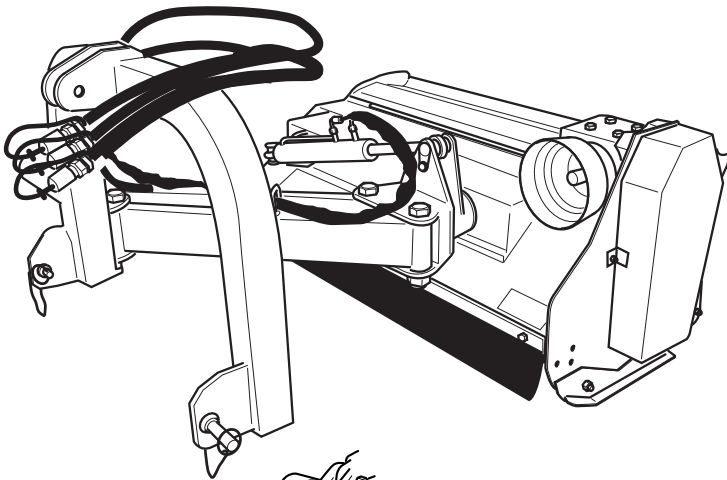

Fig. 1
MA Flail Mower

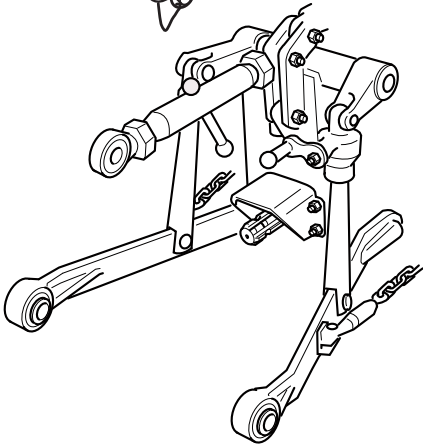

Fig. 2
Lifting group
with 3 arms

The flail mowers series MM, MA, ML, MP consist of a steel body which supports all parts of the machine; it is designed in such a way as to guarantee perfect working of the product without using high powers, in compliance with the safety standards in force.

The joint that allows the machine to tilt is fixed to the main frame; two arms are connected to the joint for lateral movement, and the three-point hitch is connected to the arms.

The machine can rotate 65° and 90° with respect to the ground by means of a hydraulic control, activated exclusively on board the tractor; moreover the flail mower can perform lateral movement by means of the hydraulically controlled arms.

The rotor is housed inside the body, supported by high-strength bearings and driven by the transmission belts which take their motion from the lateral transmission of the gearbox or gear multiplier. The rotor is dynamically balanced for smooth, vibration-free rotation.

The number of knives or hammers that the rotor is equipped with guarantees perfect shredding of the material and adequate ventilation.

The flail mower is presented at the time of purchase as in Fig. 1, and is designed to be installed on the rear part of the tractor which must be equipped with a second category "universal" 3-point rear hydraulic lift group for models MM, MA, ML and a third category type one for mod. MP suitable to withstand the weight and absorption characteristics of the flail mower.

The lift is shown in Fig.2



CAUTION!

Before performing any operation, carefully read the safety instructions provided here.

2.1 Flail mower composition

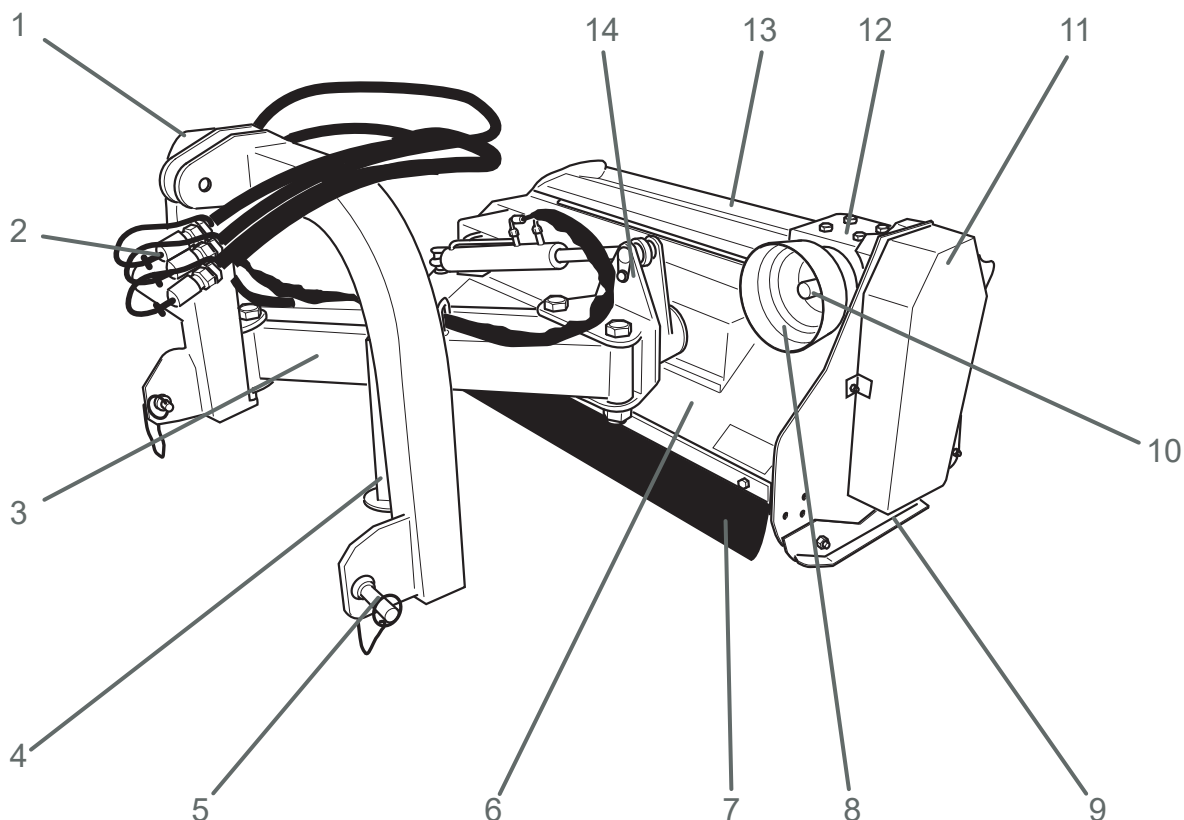

Fig. 3
Main
elements

No.	Description
1	3-point connections
2	Quick couple hydraulic fittings
3	Support and movement arm
4	Support foot
5	3rd point pivot
6	Main frame
7	"CE" rubber protection
8	Universal joint protection
9	Slide
10	Power take-off (PTO 540 RPM)
11	Drive belt casing
12	Gear box
13	Openable door for maintenance
14	Machine inclination joint



3. GENERAL SAFETY PRESCRIPTIONS

It is advisable to carefully read these notes in order to avoid dangerous situations.

- 1) In addition to the indications in this manual, it is also necessary to similarly comply with the general provisions relating to safety, envisaged for users of agricultural machinery by the legal regulations of each country.
- 2) Observe the decals on the machine, especially those relating to safety.
- 3) Start the flail mower only in a position resting on the soil and horizontal to the ground.
- 4) Never exceed the prescribed PTO speed (540 rpm).
- 5) Secure the protective pipe of the cardan shaft against rotation, by attaching the chains, in order to avoid rotation of the protective elements of the cardan shaft.
- 6) Lower the machine to ground level before putting it in the working position, making sure that there are no persons within the operating range of the machine.
- 7) Make sure that the safety devices are perfectly assembled and efficient before starting work.
- 8) Be very careful on stony ground, making sure there are no persons in the immediate vicinity.
- 9) Before any interventions on the flail mower, make sure that all the rotating elements are stationary, and turn off the tractor by removing the starter key.
- 10) When travelling on public roads, observe the rules of the Highway Code.
- 11) Exercise particular caution when attaching and detaching the implement to/from the tractor.
- 12) Before leaving the tractor, secure the implement and lower it to rest on the ground. Switch off the tractor and remove the ignition key.
- 13) Before coupling and uncoupling the machine to/from the three-point hitch, lock the controls of the tractor's hydraulic lift in order to avoid even inadvertently the hydraulic lift being activated and being able to move the flail mower.
- 14) Check that the maximum loads permitted for the three-point hitch are respected.
- 15) Perform assembly and disassembly of the cardan shaft only with the power take-off disengaged and the tractor engine off with the ignition key removed.
- 16) Before engaging the power take-off, make sure that the speed and direction of rotation of the tractor power take-off are compatible with the flail mower.
- 17) Never engage the power take-off with the engine running.
- 18) Before engaging the power take-off make sure that nobody is in the work area.
- 19) Do not allow anyone to remain near the power take-off when it is engaged.



20) Before accessing the implement, check that it is completely stopped and that the tractor has the engine off with the PTO disengaged.

21) Periodically check the correct tightening of the screws and nuts. If necessary tighten according to the tightening table in paragraph 9.3.

22) During maintenance work carried out with the tool raised, make sure that it is securely propped up, using appropriate supports.
In case of repairs, contact specialist workshops.

23) Proceed to dispose of the oil and grease observing the regulations in force.



IMPORTANT!

The flail mowers models MM, MA, ML, MP have been designed and built for agricultural use and are intended to work, in accordance with the manufacturer's instructions, within the limits indicated in this manual. The company declines all responsibility for any damage to property or persons caused by improper use of the machine.

4. IDENTIFICATION OF THE MACHINE

4.1 Identification plate



Fig. 4
Identification plate

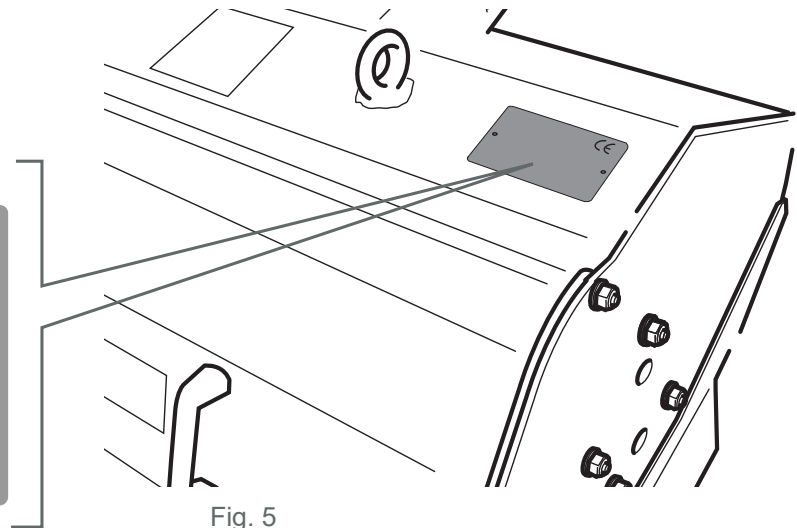

Fig. 5
Plate position

4.2 Identification codes

The Sicma flail mowers MA models are available in the following working widths and models:

Internal drive group		External drive group	
Model	Work width mm	Model	Work width mm
MPI 160	1600	MPE 160	1600
MPI 180	1800	MPE180	1800
MPI 200	2000	MPE 200	2000
MPI 230	2300	MPE 230	2300

4.3 Checking of machine upon delivery

Upon delivery of the flail mower, it is necessary to check the entire supply, making sure in particular that the use and maintenance manual which is an integral part of the machine is present.

The following items must be delivered together with the flail mower:

- no. 1 Flail mower use and maintenance manual Fig.6
- no. 1 Cardan shaft use and maintenance manual Fig.7
- no. 1 Declaration of conformity Fig.8



Fig. 6
Use and maintenance manual



Fig. 7
Cardan shaft use and maintenance manual



Fig. 8
Declaration of conformity

4.4 Technical data

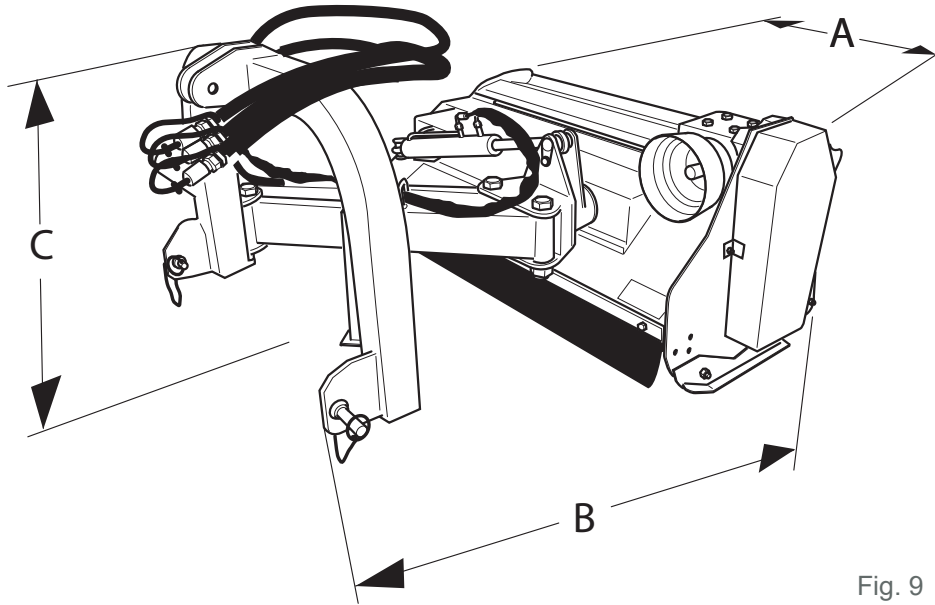
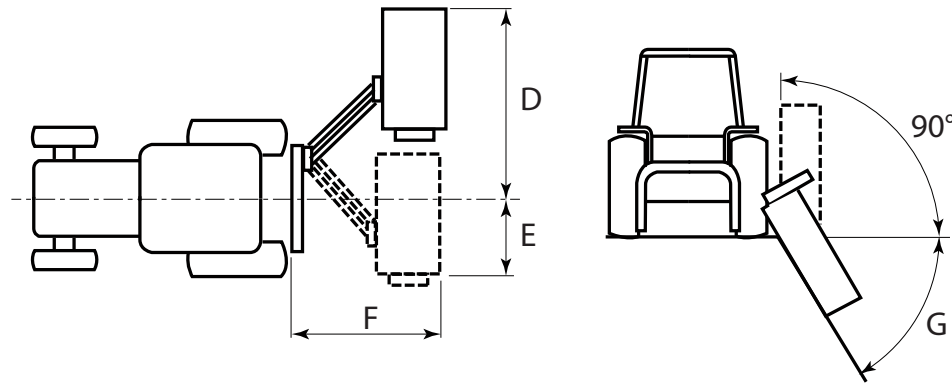

Fig. 9
Overall dimensions



TECHNICAL SPECIFICATIONS

Ref.	Model	MM		MA		MLI		MLE		MPI		MPE	
		110	125	120	140	140	160	140	160	180	200	180	200
	Working width (cm)	1100	1250	1200	1400	1330	1530	1330	1530	1800	1960	1800	1960
A	Total width (mm)	1220	1380	1316	1516	1470	1670	1540	1740	2005	2185	2005	2185
B	Total length (mm)	1440	1440	1200	1200	1600	1600	1600	1600	1750	1750	1850	1850
C	Height (mm)	850	850	700	700	968	968	968	968	1050	1050	1050	1050
	Mass – Weight (Kg)	190	200	127	147	399	429	399	429	590	630	605	645
	Number of revolutions (rpm)	540	540	540	540	540	540	540	540	540	540	540	540
	Required power (HP)	15-30	15-30	20-50	20-50	30-50	40-60	30-50	40-60	60-70	70-80	70-80	70-80
	Required power (Kw)	11-22	11-22	15-37	15-37	22-37	29-44	22-37	29-44	44-51	51-59	51-59	51-59
D	Movement (cm)	175	190	183	203	195	215	215	235	235	250	280	295
E	Movement (cm)	58	58	58	58	65	65	65	65	85	85	115	115
F	Maximum dist. (cm)	144	144	145	145	154	154	154.5	154.5	175	175	180	180
G	Gradient	65°	65°	65°	65°	66°	66°	66°	66°	70°	70°	70°	70°
	Standard Y Knives	-	-	40	48	40	44	40	44	48	48	48	48
	Standard Hammer	-	-	20	24	20	22	20	22	24	24	24	24

5. SAFETY STANDARDS: STICKERS AND WARNINGS

THE STICKERS PLACED ON THE MACHINE ARE AN INTEGRAL PART OF THE SAME!

Any stickers that are damaged, or in any case not legible, must be requested from SICMA and immediately replaced.

SICMA declines all responsibility for failure to comply with the safety and prevention regulations contained in this manual.



ATTENTION!

The stickers and plates containing warnings and notifications are an integral part of the machine.

Fig. 10
Location of safety stickers

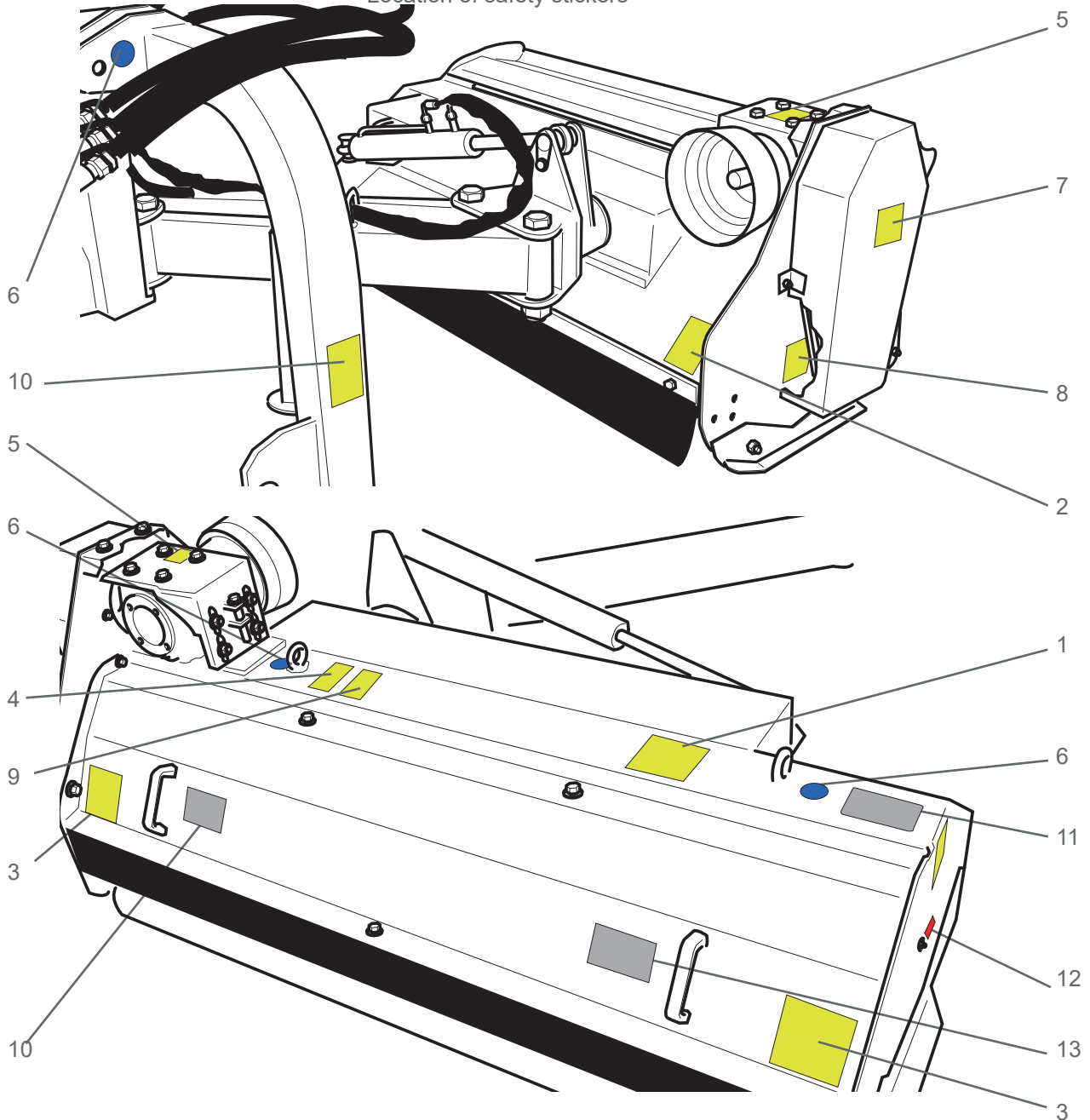

ATTENTION VERY IMPORTANT

The position of the safety stickers is the same for all embankment Shredder models.

5.1 Description of stickers



ATTENTION!!!

Read the explanation of all stickers carefully.

- | | | | | | | | | | | | | | | | | | | | | | | | | | | | | | | | | |
|---|--------------|--|----|---|--|--|-----------|---|--|--|------|--------------|--|-------|---------|--|-----------|-------|--|------|------|--|------|--------|--|-------|---------|--|---------------|--|--|--------------------------------------|
| 1 | | <p>Attention: read all instructions and safety rules carefully before using the machine.
Switch off the engine and remove the key before carrying out maintenance or repairs.</p> | 8 | | <p>Hand injury Hazard: keep the safety guards in place during operation.</p> | | | | | | | | | | | | | | | | | | | | | | | | | | | |
| 2 | | <p>Foot injury hazard: rotating tools, maintain a safe distance from the machine.</p> | 9 | | <p>Danger of falling materials or raised tools. Respect the safety distance.</p> | | | | | | | | | | | | | | | | | | | | | | | | | | | |
| 3 | | <p>Throwing of objects against any part of the body: keep a safe distance from the machine.
Risk of injury to the hands: do not open or remove the safety guards while the machine is in motion.</p> | 10 | | <p>Throwing of objects against any part of the body: keep a safe distance from the machine.
Risk of injury to the hands: do not open or remove the safety guards while the machine is in motion.</p> | | | | | | | | | | | | | | | | | | | | | | | | | | | |
| 4 | | <p>Crushing hazard, dangerous area caused by moving of the machine.</p> | 11 | <table border="1" style="font-size: 8px; border-collapse: collapse; width: 100%;"> <tr> <td colspan="2" style="text-align: center;">SIGMA</td> <td style="text-align: right;">CE</td> </tr> <tr> <td colspan="3" style="font-size: 6px;">SICMA s.p.a. - Via Cernaia, 28 - 01100 Montefiascone (VT) - Italy
Tel: +39 0761 80001 - Fax: +39 0761 80002 - Email: info@sigma.it</td> </tr> <tr> <td>Type</td> <td colspan="2">Trinciatrice</td> </tr> <tr> <td>Model</td> <td colspan="2">MLU 160</td> </tr> <tr> <td>Serial No</td> <td colspan="2">00211</td> </tr> <tr> <td>Year</td> <td colspan="2">2011</td> </tr> <tr> <td>Mass</td> <td colspan="2">550 Kg</td> </tr> <tr> <td>Input</td> <td colspan="2">540 rpm</td> </tr> <tr> <td colspan="3" style="text-align: center;">MADE IN ITALY</td> </tr> </table> | SIGMA | | CE | SICMA s.p.a. - Via Cernaia, 28 - 01100 Montefiascone (VT) - Italy
Tel: +39 0761 80001 - Fax: +39 0761 80002 - Email: info@sigma.it | | | Type | Trinciatrice | | Model | MLU 160 | | Serial No | 00211 | | Year | 2011 | | Mass | 550 Kg | | Input | 540 rpm | | MADE IN ITALY | | | <p>CE identification plate (p.9)</p> |
| SIGMA | | CE | | | | | | | | | | | | | | | | | | | | | | | | | | | | | | |
| SICMA s.p.a. - Via Cernaia, 28 - 01100 Montefiascone (VT) - Italy
Tel: +39 0761 80001 - Fax: +39 0761 80002 - Email: info@sigma.it | | | | | | | | | | | | | | | | | | | | | | | | | | | | | | | | |
| Type | Trinciatrice | | | | | | | | | | | | | | | | | | | | | | | | | | | | | | | |
| Model | MLU 160 | | | | | | | | | | | | | | | | | | | | | | | | | | | | | | | |
| Serial No | 00211 | | | | | | | | | | | | | | | | | | | | | | | | | | | | | | | |
| Year | 2011 | | | | | | | | | | | | | | | | | | | | | | | | | | | | | | | |
| Mass | 550 Kg | | | | | | | | | | | | | | | | | | | | | | | | | | | | | | | |
| Input | 540 rpm | | | | | | | | | | | | | | | | | | | | | | | | | | | | | | | |
| MADE IN ITALY | | | | | | | | | | | | | | | | | | | | | | | | | | | | | | | | |
| 5 | | <p>Use the 540 rpm PTO.</p> | 12 | | <p>Greasing point</p> | | | | | | | | | | | | | | | | | | | | | | | | | | | |
| 6 | | <p>Attachment point for lifting of the machine.</p> | 13 | | <p>Shredder dimension plate</p> | | | | | | | | | | | | | | | | | | | | | | | | | | | |
| 7 | | <p>Foot injury hazard: keep a safe distance from the machine.</p> | | | | | | | | | | | | | | | | | | | | | | | | | | | | | | |

6. UNLOADING AND UNPACKING

Unloading of the flail mower must be performed with the utmost care by operators to avoid damage to the machine and harm to the operators themselves.



CAUTION!

Make sure that during the loading and unloading operations and when moving the machine, there are no persons not involved in the work in the range of operations.

Unloading from the means of transport must be performed using suitable forklift trucks or cranes suitable for use. It is mandatory to use suitable "CE" approved lifting chains or belts



CAUTION!

Check that the load capacity of these vehicles is adequate for the weight of the machine to be lifted. The weight is shown on the machine identification plate (Chap. 4.1).



CAUTION!

The means of transport must allow perfect positioning of the machines, the base of which must rest on the loading bed of the vehicle and must also not be stacked. This could cause deforming of the machine structure.

LIFTING EQUIPMENT
Fig. 11 Lifting equipment

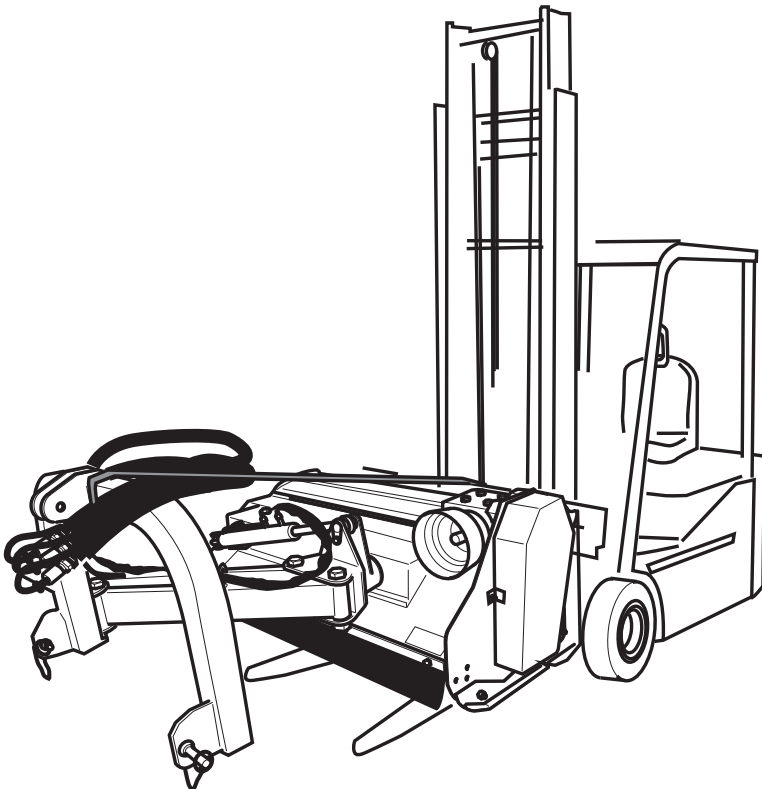

LIFTING METHOD
Fig.12 Lifting or attachment points

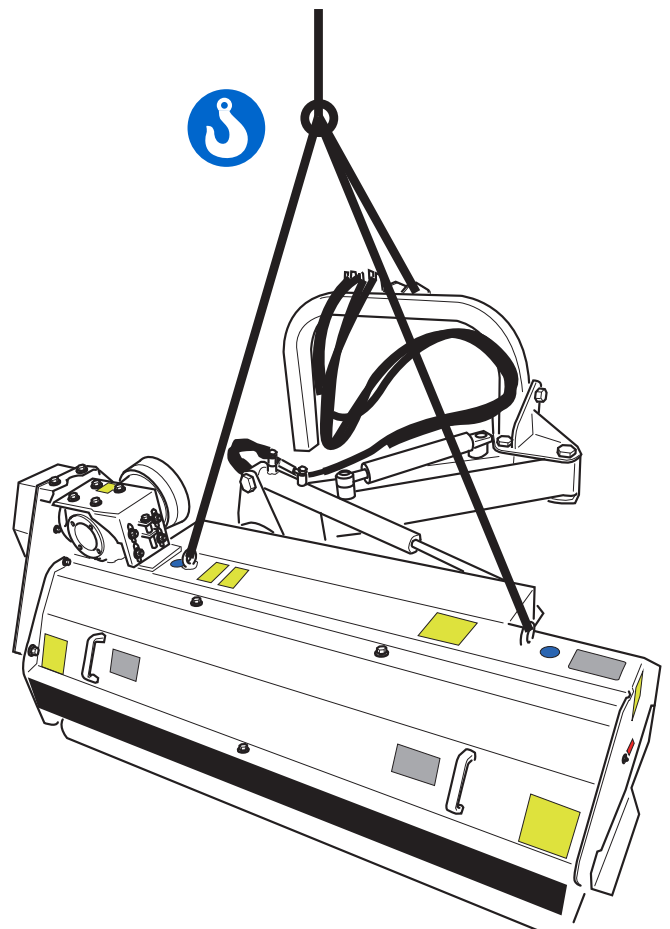

Fig. 13
Adjustable third point

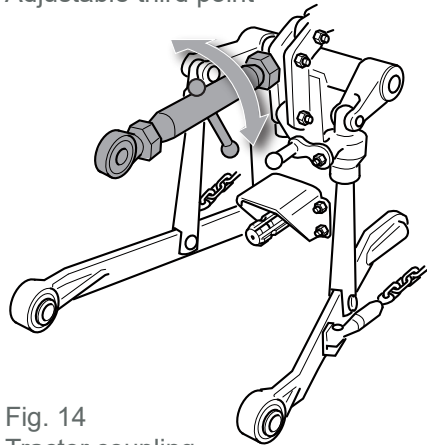

Fig. 14
Tractor coupling

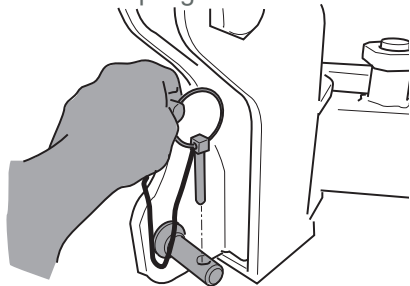

Fig. 15
Tractor coupling

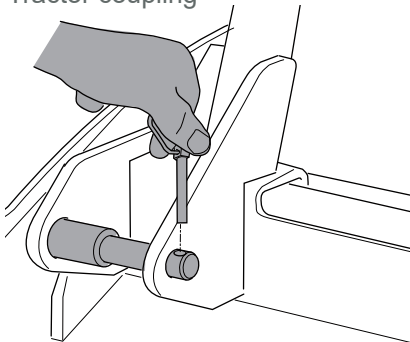

Fig. 16
Tractor coupling

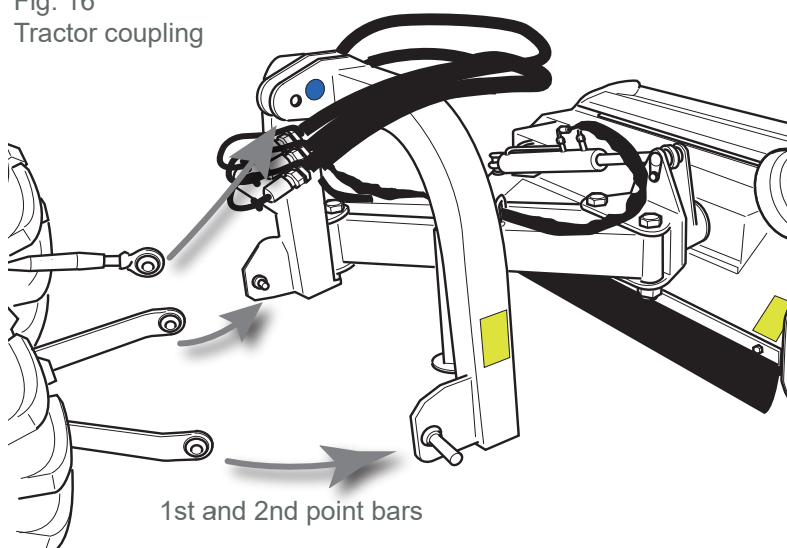
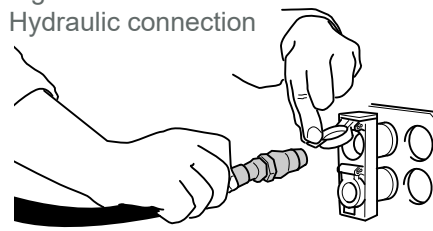

Fig. 17
Hydraulic connection



7. MACHINE INSTALLATION

7.1 Application to the tractor

As the lifting bars of each tractor have their own length, it is necessary to determine for each machine the suitable position for the flail mower, then lengthening or shortening the upper link bar of the tractor (Fig. 13), and if necessary shortening the cardan shaft following the instructions in chap. 7.4.

The connection of the tractor to the flail mower must be performed as in figure 14-15-16-17.

The flail mowers models MM, MA and ML can be applied to tractors equipped with a universal three-point hitch (Fig. 2) of 1st and 2nd category, while the MP is applicable to tractors with 2nd and 3rd category hitches.

CAUTION!

Do not stand between the tractor and the flail mower during the coupling operations.

PROCEED TO CONNECTION AS FOLLOWS:

- 1) Approach the lifter bars, placing them inside the flail mower attachments.
- 2) Insert the lifting rods into the flail mower pins and lock them with the appropriate snap pins (Fig. 14-15).
- 3) Insert the cardan shaft making sure it is perfectly locked.
- 4) Lock the lift bars in place with the dedicated chains and parallel tensioners.

5) Connect the third point of the lifting group, checking that the machine is perfectly level with respect to the ground, as indicated in paragraph 8.1.

6) Connect the hydraulic couplings to the tractor oil distributors (Fig. 17). Work with the tractor off.

7.2 Transporting the Flail Mower

During transportation and whenever lifting is necessary, the tractor lifting group should be adjusted so that the flail mower is raised above the ground by approximately 35 cm (Fig. 18).



CAUTION!

Near the three-point hitch there are dangers of crushing and cutting injuries.



CAUTION!

Before lifting the flail mower, wait for the transmission parts and the shredding rotor to stop.



CAUTION!

During transportation of the flail mower, unhook the cardan shaft.

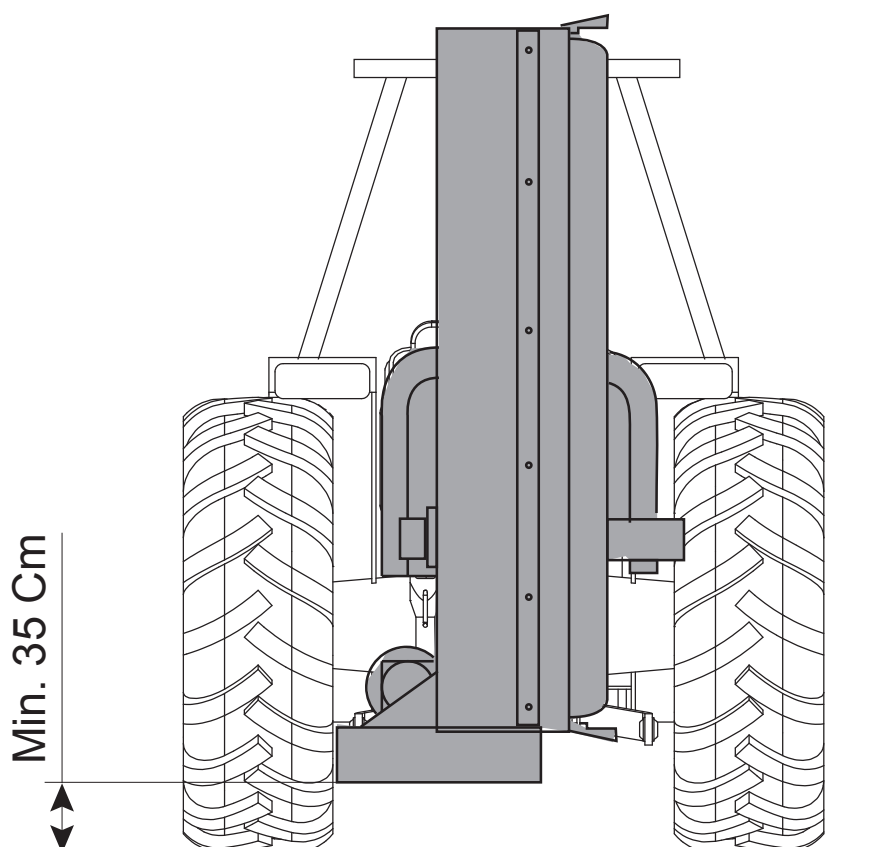

Fig. 18
Transport height of the flail mower

7.3 Special productions on the tractor



CAUTION!

It is necessary to protect with Plexiglas walls or very thick fine-meshed metal grating all parts or areas that can be struck by the throwing of objects or stones.



CAUTION!

Below is the example of an agricultural tractor cab, with metal mesh protections.



CAUTION! Adequate protection prevents damage to the agricultural tractor and to yourself.

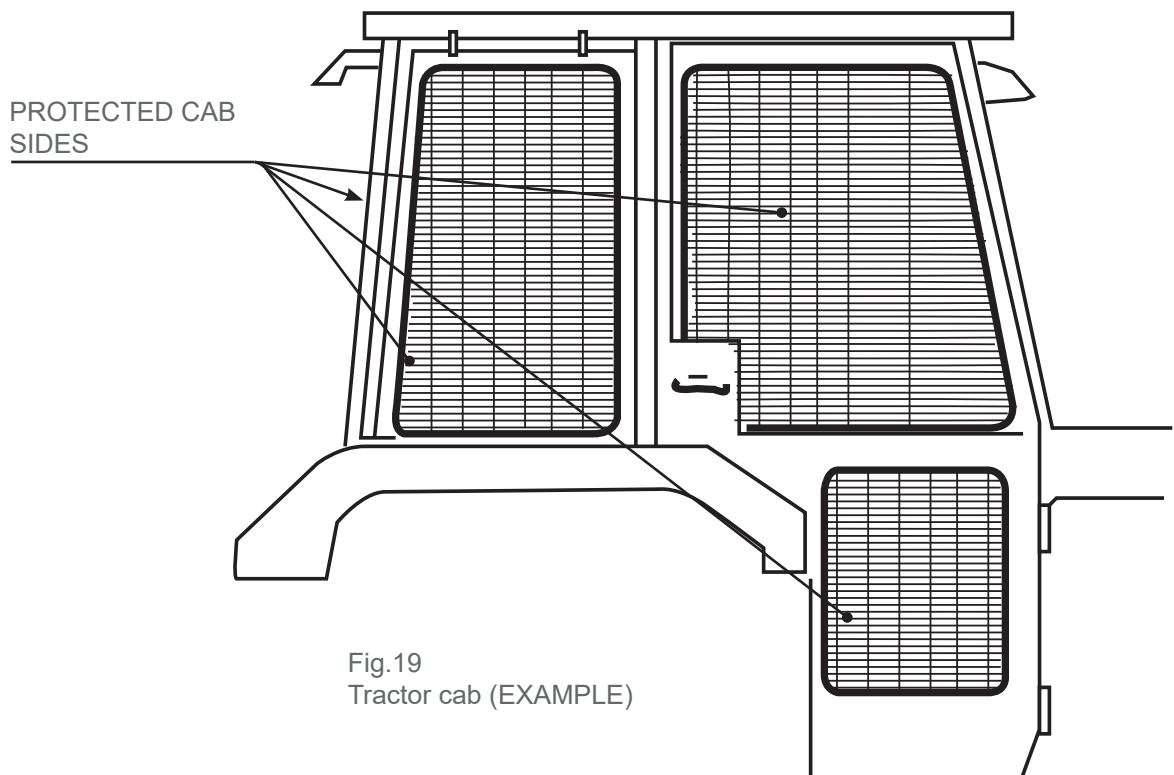

VERY IMPORTANT:

ALWAYS USE TRACTORS EQUIPPED WITH "CE" CAB

7.4 Adapting the cardan shaft

The cardan shaft supplied with the flail mower is of standard length; it is therefore necessary to adapt it to the tractor to be used. For this operation it is advisable to contact authorised workshops.

1) Remove the shaft in two halves, apply one part to the PTO in the tractor and the other to the PTO in the flail mower. Raise and lower the hydraulic lift to find the minimum sliding length and indicate it on the shaft.

2) Cut the external plastic tube to the excess length plus 30 mm, and the internal tube of the same size (Fig.20); then reassemble it carefully making sure that the joint forks are coplanar.

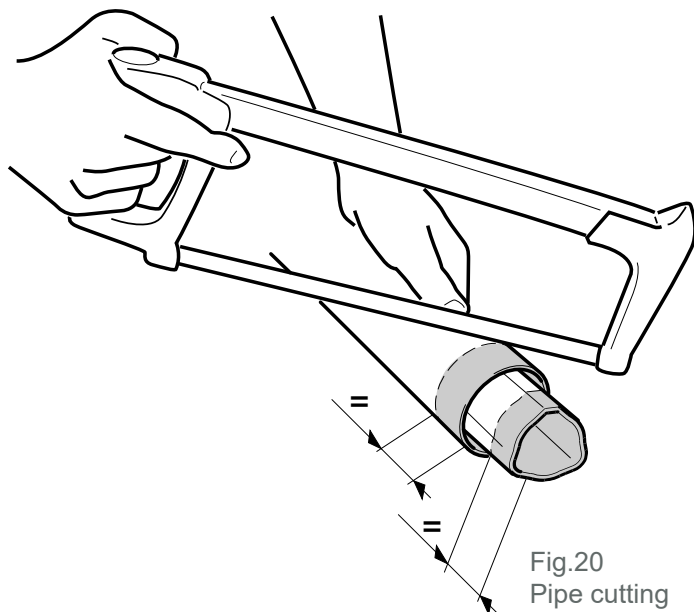

3) Operate the lift and check that the cardan slides smoothly, and that there remains a minimum part of overlap of the pipes of not less than 100mm.

4) ATTENTION! Check the length of the cardan shaft upon each change of the tractor.

5) The end of the cardan equipped with torque limiter and any free wheel must be fitted on the power take-off of the flail mower.

6) The maximum permitted angle of the cardan is 15° (Fig.21).

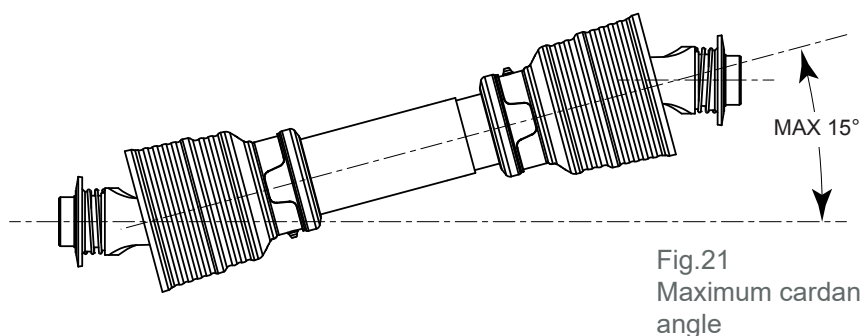

7) Attach the chains supplied with the cardan shaft to fixed points to prevent rotation of the protections.

8) Lubricate the cardan following the manufacturer's instructions (see cardan shaft use and maintenance manual).

8. RULES FOR USING THE FLAIL MOWER

The application of additional equipment to the tractor will unbalance the weights on the axles. It is advisable to balance the weights as much as possible by adding ballast to the front of the tractor.

The necessary ballast can be calculated using the formula below (Fig. 22).

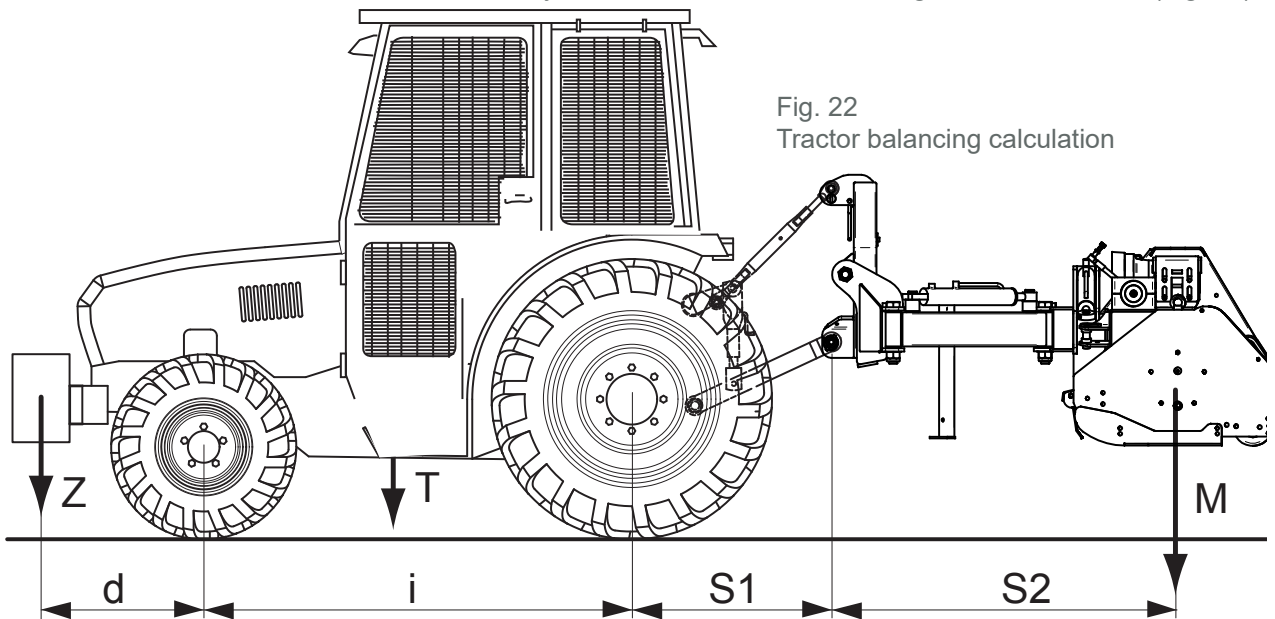

Fig. 22
Tractor balancing calculation

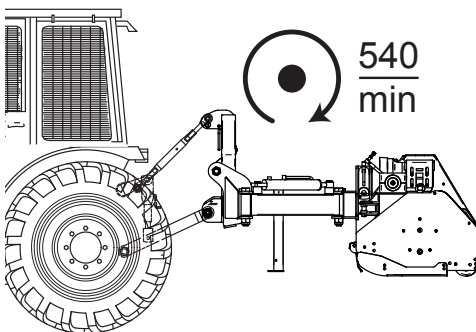

Fig. 23
Max revs. limit

$$M \cdot (S_1 + S_2) \leq 0,2 \cdot T \cdot i + Z \cdot (d + i)$$

$$M \leq 0,3T$$

$$Z \geq \frac{M \cdot (S_1 + S_2) - 0,2 \cdot T \cdot i}{d + i}$$

i = = wheelbase

d = distance between the front axis and the ballasts

S1 = distance between centre of the rear axle and centre of the lower connection points

S2 = distance between the centre of lower coupling points and centre of gravity of the flail mower

T = weight of the tractor + 75Kg (operator)

Z = mass of the ballast

M = the mass of the machine

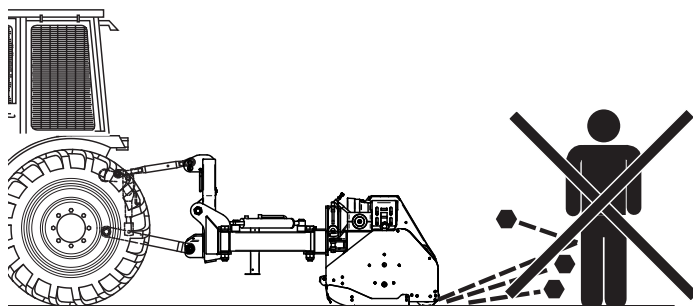

Fig. 24
Remain at a distance

Before starting the shredding operation, check the following points:

- Check the coupling of the safety chain of the cardan shaft;
- make sure that the machine is parallel to the ground and resting on the ground itself (Fig. 26);
- check all the safety devices of the flail mower;
- make sure that no-one is near the work area of the flail mower (Fig.24);
- engage the power take-off slowly and accelerate the tractor, avoiding exceeding the maximum rotation limit of the power take-off of 540 rpm (Fig. 23).



CAUTION!

The applied equipment can only be operated through the cardan shaft complete with the necessary safety devices for overloads, and equipped with the relative protection secured with a dedicated chain.

8.1 Position of the machine with respect to the ground

Before starting work, check the position of the knives with respect to the ground.

In the case that these touch the ground, adjust the levelling and support roller, and the side skids.



CAUTION!

Before starting any check or adjustment operation on the flail mower, stop the tractor, remove the ignition key and lock the vehicle with the dedicated parking brake.

Adjusting the levelling roller and soil scraper

To adjust the levelling and support roller, proceed as follows:

- 1) loosen the fixing screws "A", located at the ends of the levelling roller;
- 2) remove the fixing screws "A1";
- 3) loosen the screws "B" of the soil scraper;
- 4) proceed to adjust the height of the roller, checking that it is perfectly parallel to the machine;
- 5) reach the desired position, reinsert the screws "A1" and fix them;
- 6) adjust the position of the scraper so that it is approximately 2 mm from the roller and lock the screws "B".

Fig. 25
Roller and soil scraper adjustment

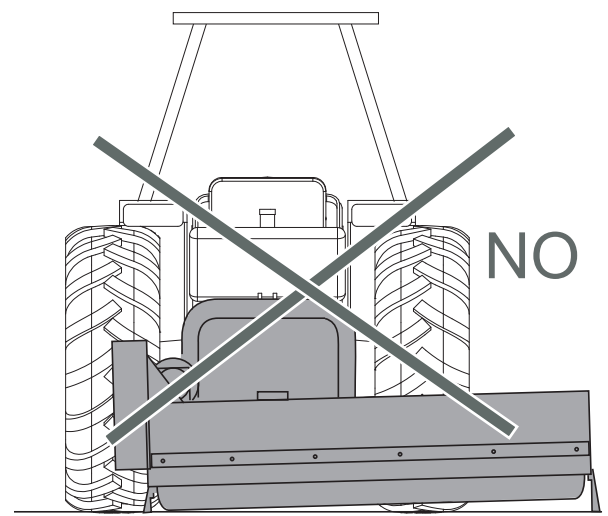
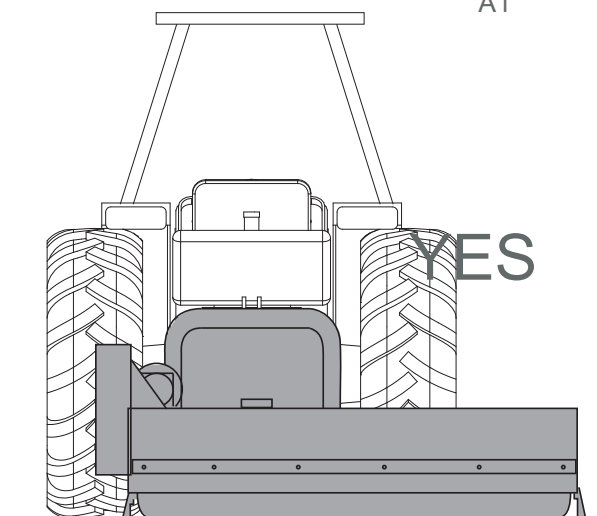
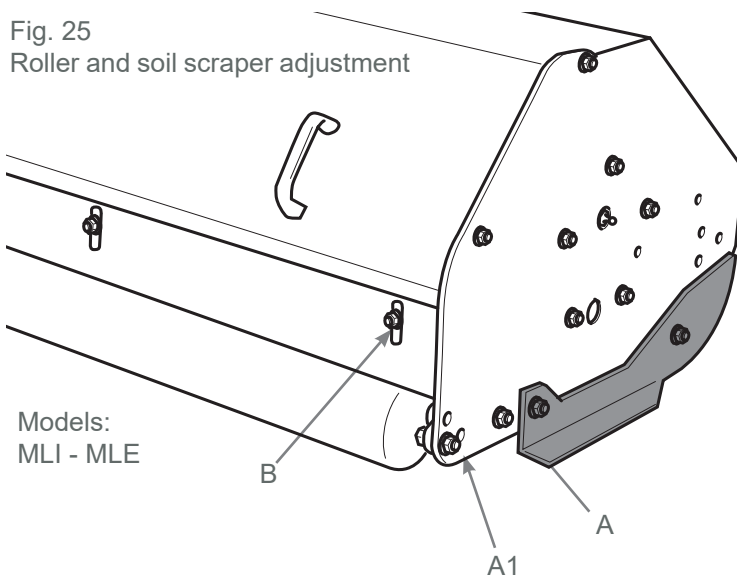

Fig. 26
Correct roller position

8.1.0 Integrated safety system with hinge

Thanks to the presence of a particular anchoring system and the installation of a specific hinge (A), the MP shredder can easily continue its path even in the presence of obstacles and protrusions on the ground and allows maintaining of its stability even in the event of uneven ground (Fig. 27).

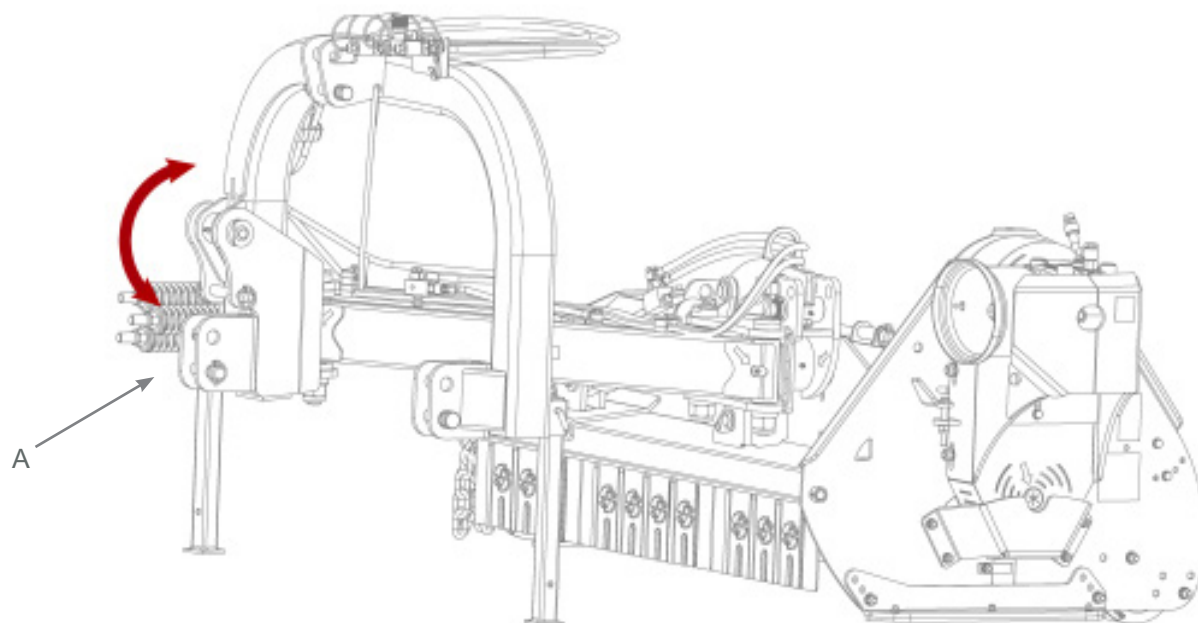

Fig. 26a
Unevenness correction system

8.1.1 Additional diverter

The SICMA additional diverter is a fundamental accessory if the tractor does not have 2 hydraulic levers.

To use the diverter, the following are necessary:

- 1) If the diverter is not already connected to the machine, attach the four hydraulic connections (A, B, C, D) of the machine in front of the diverter (Fig. 26b).
- 2) Connect the two hydraulic connections on the sides of the diverter to the tractor (Fig 26c).

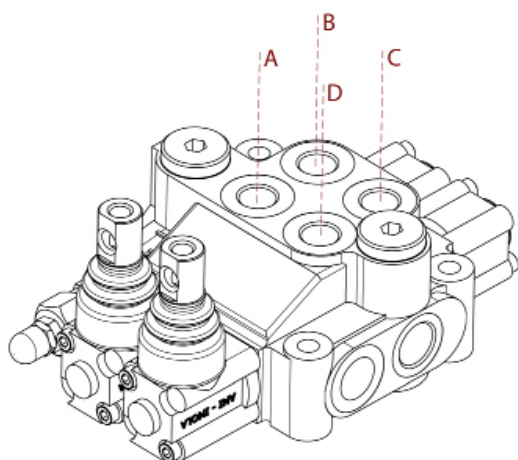

Fig. 26b
Diverter - machine connection

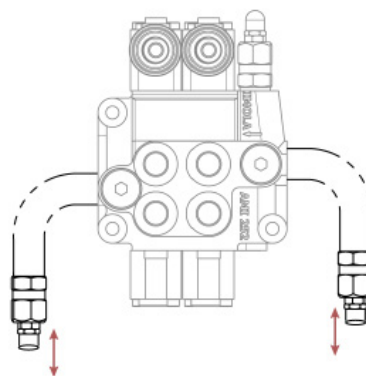

Fig. 26c
Diverter - tractor connection

8.1.2 Skids adjustment

Adjust the position of the skids so that the knives or mallets do not touch the ground (Fig. 28). Correct adjustment prevents the tools from touching the ground, even when it is uneven. Failure to follow these guidelines means that the knives will quickly wear out, causing the tool-holder shaft to become unbalanced, thus causing anomalous and premature deterioration of the drive belts.

- 1) Remove the fixing screws "A" of the skids (Fig. 27).
- 2) Adjust the height of the skids so that they are lower than the lower point of the knives or hammers.
- 3) Once the optimal position has been reached, lock the fixing screws "A".
- 4) Check that the skids are at the same height with respect to the flail mower frame.

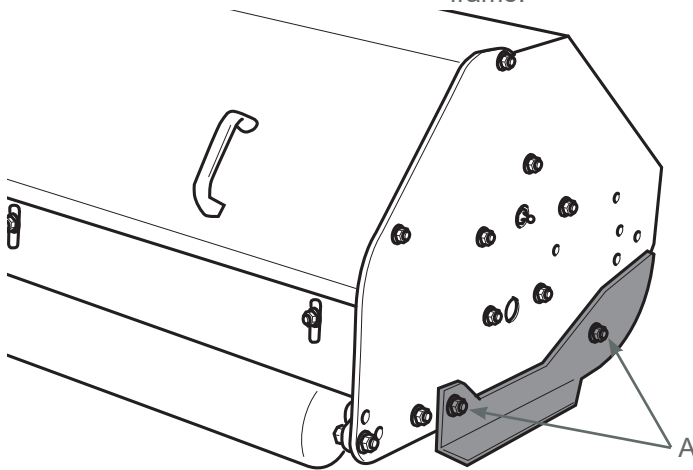

Fig. 27
Adjusting the skids

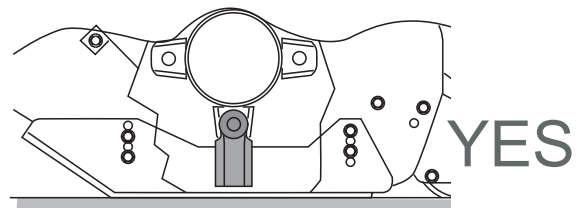
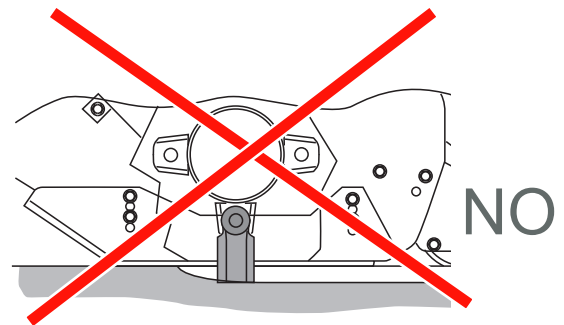

Fig. 28
Correct skid position

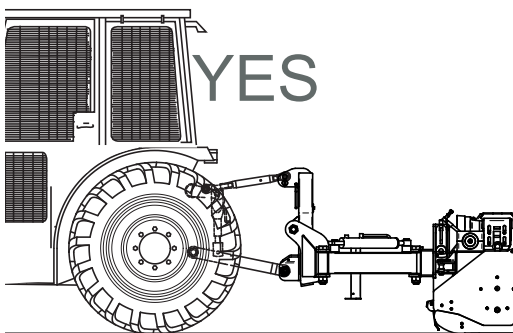

Fig. 29
Regular position



CAUTION!

It is forbidden to work with knives or hammers in contact with the ground

8.1.3 Third arm adjustment

The machine must be perfectly parallel to the ground in order to obtain a perfect work result (Fig. 30).

The adjustment is carried out by acting on the third point of the tractor (Fig. 31).

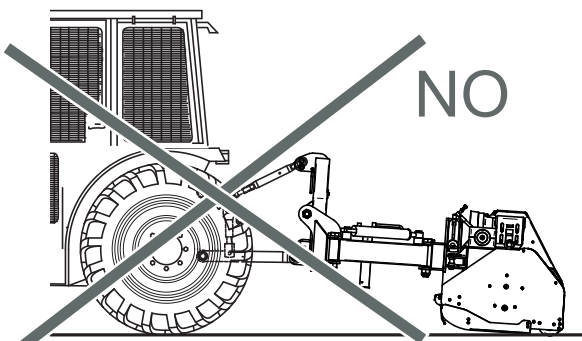

Fig. 30
Incorrect position

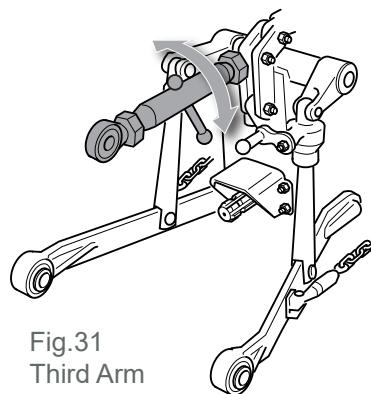

Fig.31
Third Arm
Adjustable

8.1.4 Machine work positions: movement and inclination

Once the work point is reached, the MM, MA, ML, MP flail mowers are equipped with a mobile hydraulically controlled attachment for lateral movement with respect to the tractor (Fig. 32), and a joint for inclination with respect to the ground (Fig. 33) whose speed is adjustable by means of a manually operated choke (Fig. 35).

The lateral movement and inclination commands are both performed by hydraulic cylinders (Fig. 34), connected to the tractor's hydraulic distributors, with mechanical control.

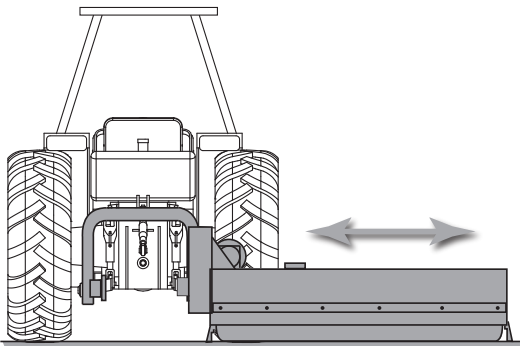

Fig.32
Lateral movement

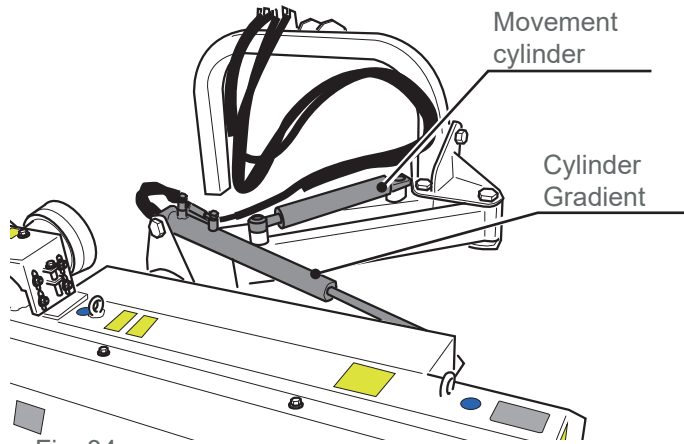

Fig. 34
Handling cylinders

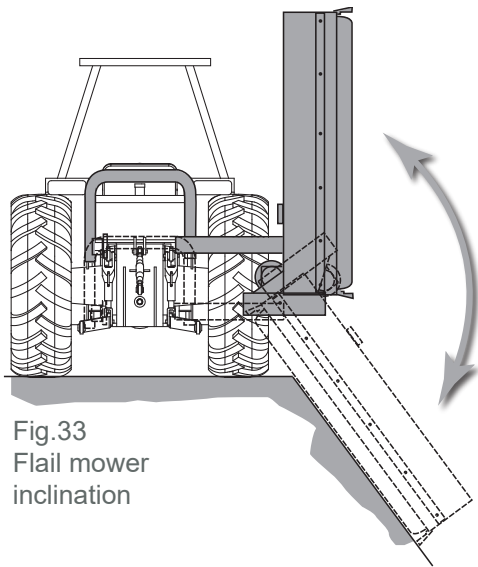

Fig.33
Flail mower inclination

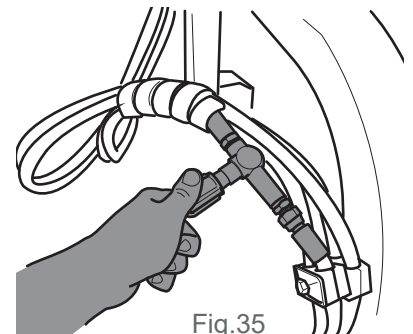

Fig.35
Flail mower inclination speed regulator

8.1.5 Starting to work the soil

CAUTION!

The machine can be dangerous in certain work situations. To avoid dangerous situations it is advisable to follow these recommendations:

CAUTION!

During the shredding work do not exceed the speed of 10 Km/h.

CAUTION!

The MM, MA, ML, MP flail mowers have been designed to work exclusively in the direction of travel (Fig. 36).

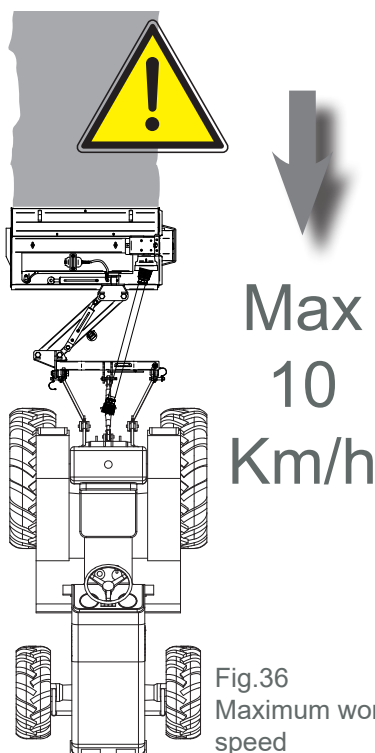

Fig.36
Maximum work speed

- 1) To avoid dangerous situations, do not work with this machine when feeling tired; alertness decreases and the attention required by the operator also decreases.
- 2) Before starting work, make sure there are no persons or animals in the immediate vicinity.
- 3) Before carrying out the adjustment operations, it is necessary to disconnect the power take-off, stop the tractor engine and wait for the flail mower to be completely stopped and resting on the ground.
- 4) It is necessary to read all the safety requirements and methods of use of the machine.
- 5) In case of uncertainty about how to use the flail mower, it is necessary to contact the manufacturer of the machine.

9. ROUTINE MAINTENANCE

PERIODIC MAINTENANCE OPERATIONS ARE ESSENTIAL FOR THE EFFICIENCY AND CORRECT OPERATION OF THE MACHINE.



CAUTION!

When carrying out a maintenance operation, it is necessary to operate as follows:

- disengage the power take-off and switch off the tractor engine
- place the equipment on the ground

Do not stand behind the flail mower for any reason when the tractor is running.

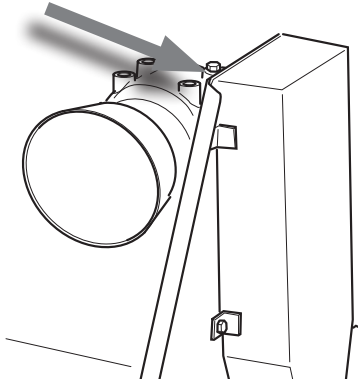

Fig. 37 MIP oil control and top-up

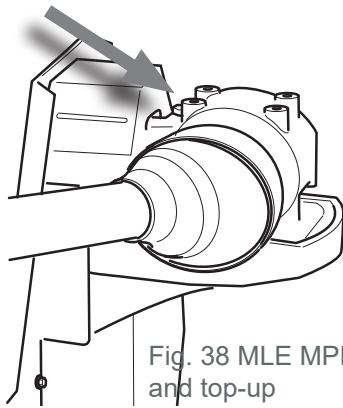

Fig. 38 MLE MPE oil control and top-up

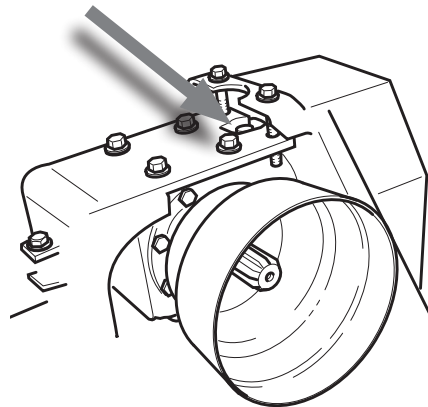

Fig. 39 MLI oil control and top-up

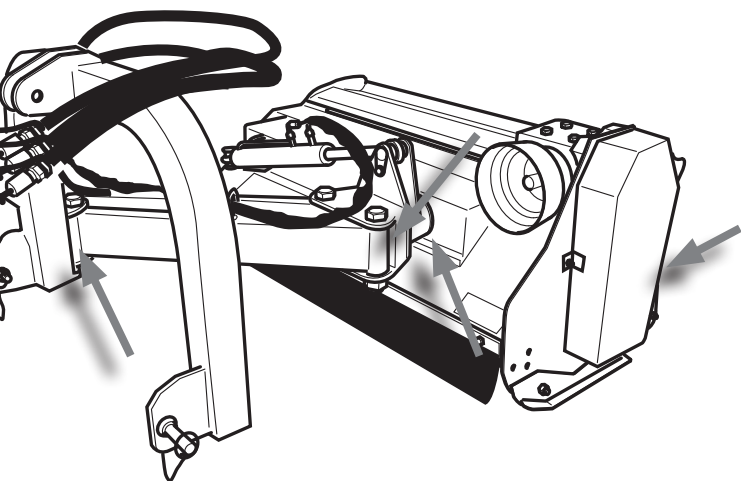
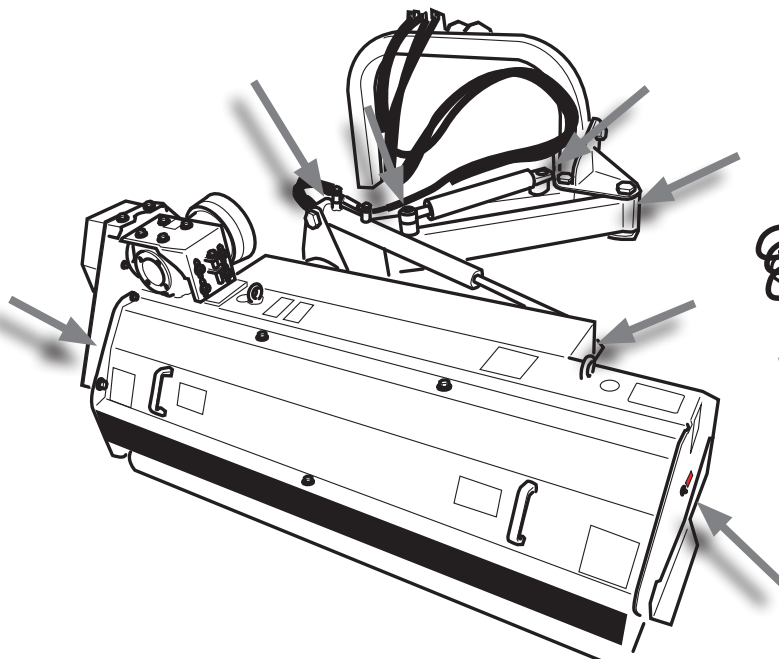

Fig. 40
Lubrication points

RESPECT THE OIL USE TABLE.

9.1 Adjusting the belts and replacement

The belts must be checked and adjusted after the first 5 hours of work: then check the tension every 50 hours of work. Avoid replacing just a single belt in order to avoid compromising the even tensioning of the belts.

CAUTION!

All the operations to check and replace the belts must be carried out with the tractor engine off, the power take-off disengaged, the parking brake engaged and the ignition key removed.

It is necessary to follow these instructions for your own safety and for that of others.

Belt replacement operations:

- 1) Remove the cover protection and the belt protection cover (casing) by loosening the screws Z (Fig. 41).
- 2) Loosen the fastening bolts H of the multiplier support (Fig.41).
- 3) To replace the belts, move the drive unit to the lowest position by loosening the lock nuts K of the tension screw J and loosen the tension screws J. Remove the belts one by one and replace them with a new set.
- 4) Check the tension of the belts in the centre; by pressing in the centre with a force of approximately 9 Kg it must be necessary to perceive a deviation of around 8 mm (Fig. 42).
- 5) Fasten the fixing screws of the transmission unit while keeping the guide axis parallel to the machine. A transmission not parallel to the machine causes anomalous wearing of the belts.
- 6) Refit the belt protection cover or casing correctly.

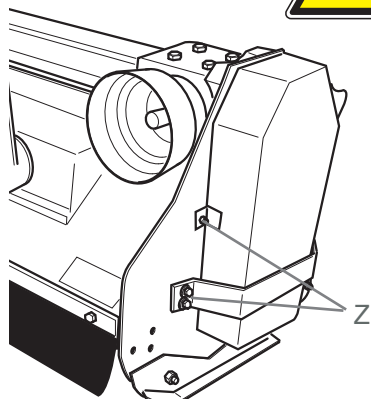

Fig. 41
BELTS CONTROL AND
REPLACEMENT

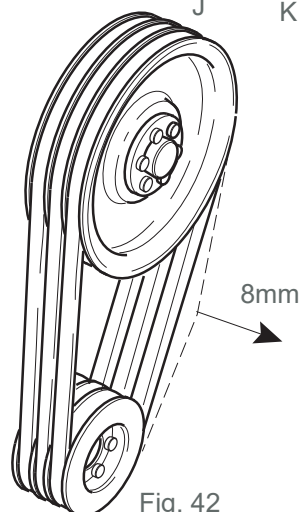
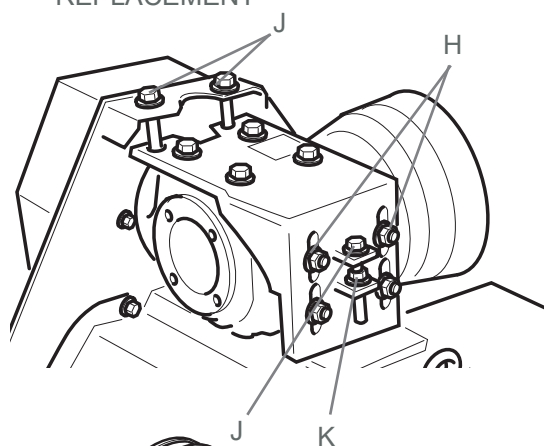

Fig. 42
BELTS TENSION

9.2 Replacing the knives or hammers

Every 100 work hours make sure that the knives or hammers are in a good condition. If some knives or hammers are missing, broken, or excessively worn, replace the entire set of knives. If only a part of these is replaced, the remaining worn parts cause an imbalance of the rotor during operation with consequent engagement of high vibrations which damage the machine and the rotor itself.

IT IS VERY IMPORTANT TO ALSO CHECK THE STATE OF WEAR OF THE SCREWS; IN THE EVENT THAT THE SCREWS SHOW SIGNS OF WEAR, IT IS NECESSARY TO REPLACE THEM WITH THE ORIGINAL ONES OF THE MANUFACTURER.



CAUTION!

Do not replace the knives while keeping the flail mower raised from the tractor. It is extremely dangerous for your safety and for that of others.

IT IS NECESSARY TO USE ORIGINAL Sicma KNIVES OR HAMMERS AND SCREWS

To replace the knives or hammers, carefully follow the instructions below:

- 1) With the tractor engine off, disconnect the cardan shaft from the two power take-offs.
- 2) For models without an opening hood, restart the tractor and lift and place the flail mower on sturdy and stable stands, high enough to make it easy to replace the tools (Fig. 43). Otherwise, access the rotor compartment by opening the hood.
- 3) Turn off the tractor leaving the first gear engaged and engage the emergency brakes.
- 3) Replace the knives or hammers as shown in figures 44 and 45 and carefully fix the screws on the nut making sure they are firmly tightened.
- 4) After replacing the knives or hammers, proceed in the reverse order of the operations described above, paying close attention to the danger of crushing.
- 5) For this operation it is advisable to contact Sicma authorised centres, who will also carry out a test of the machine to check that the new knives or hammers do not cause abnormal vibrations.

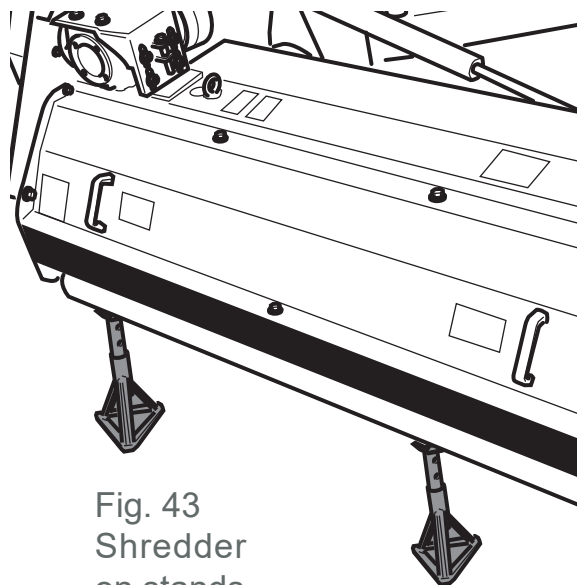

Fig. 43
Shredder
on stands

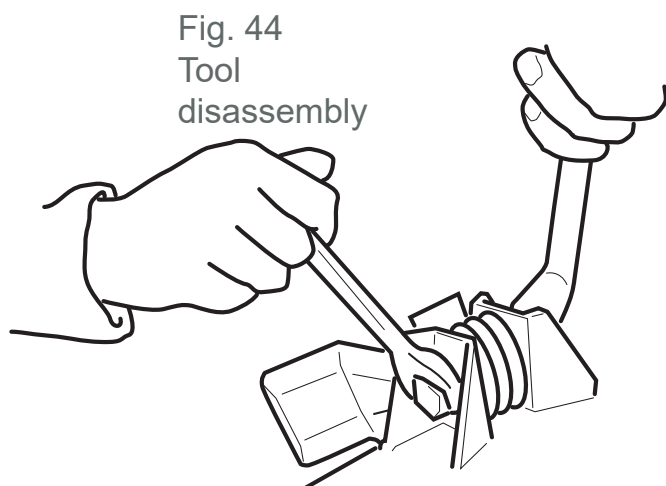

Fig. 44
Tool
disassembly

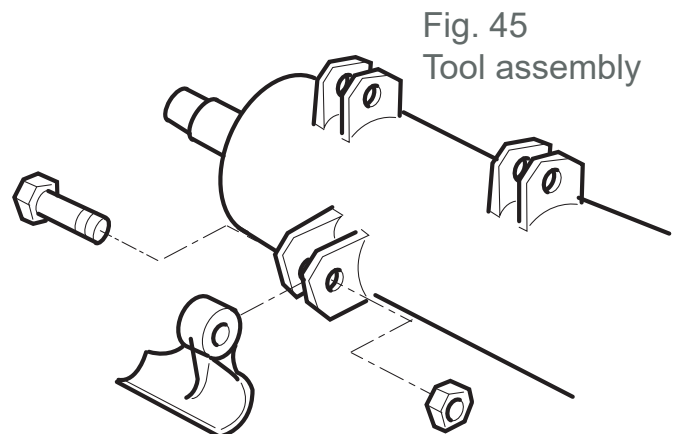

Fig. 45
Tool assembly

9.3 Table of tightening torques

Check the efficiency of all screws and bolts every day. If necessary, replace them immediately, requesting them from the manufacturer, and reposition them (screws, washer, nut) in the same sequence as they were removed.

TIGHTENING TORQUES				
Threading	Bolt class			
	8.8		10.9	
	Nm	Lb-ft	Nm	Lb-ft
M6	11	8.5	17	12
M8	28	20	40	30
M10	55	40	80	60
M12	95	70	140	105
M14	150	110	225	165
M16	240	175	305	225
M18	330	250	475	350

9.4 Special accessories: OPENABLE HOOD



CAUTION! HAZARD

IT IS FORBIDDEN TO USE THE FLAIL MOWER WITH THE HOOD OPEN

The flail mowers models MA, ML, have a special opening hood, to facilitate maintenance.



CAUTION!

IT IS FORBIDDEN TO START THE TRACTOR WITH THE HOOD OPEN!
Before opening the hood for maintenance, it is necessary to turn off the tractor, remove the ignition key from the dashboard and disconnect the cardan shaft.

To open the hood, loosen the locking screws, open the hood and lock it by re-inserting and tightening the bolts into the corresponding holes. To close, carry out the operations in reverse order.

N.B.: the doors vary according to the flail mower model.

Once the maintenance operations have been carried out, reposition the hood in the initial configuration.

BEFORE STARTING THE TRACTOR CAREFULLY CHECK THE CLOSURE OF THE HOOD AND THE TIGHTENING OF THE RELATIVE SCREWS.

The company Sicma, DECLINES ALL LIABILITY for any material or physical damage caused by the flail mower if the user does not comply with these safety requirements.

9.5 Lubricants table

LUBRICANT OIL AND GREASE USE TABLE						
INTERVENTION	ROLOIL	MOBIL	CASTROL	ESSO	AGIP	SPRIG OIL
TRANSFER BOX	EP 1000	MOBILGEAR 636	ALPHA SP 680	SPARTAN EP 680	BLASIA P1000	
REDUCER	VARIAX 80W90	MOBILAND HP 80W-90	HIPOY B80W-90EP	GEAR CZ80W-90	ROTRA MP 80W-90	GEAR 150 EPLITEX EP2
GENERIC	LITEX EP2	MOBILUX 2	SPHEEROL APT 2	BEACON 2	GR MU 2	
SPECIAL FOR BEARINGS	ISOMOV 2	MOBILGEAR SPECIAL	SPHEEROL LMM	MULTIPURPOSE MOLY	GR SM	
IMP. HYDRAULIC	LI46	PTE25	HYSPIN AWS 46	NUTO 46	OSO 46	

10. PROBLEMS AND SOLUTIONS

PROBLEMS	CAUSE AND SOLUTION
Excessive vibrations	<p>Excessive wear of knives or hammers</p> <ul style="list-style-type: none"> • excessively worn knives or hammers. • missing or broken knives or hammers. • foreign bodies wound on the rotor. • loose screws or nuts; check the tightness. • Tractor PTO not compliant, check PTO rpm number • damage to the shredder rotor; contact specialist assistance centres.
Slipping of belts	<p>The knives or hammers touch the ground, adjust the rear roller or skids correctly.</p> <ul style="list-style-type: none"> • check the belt tension after the first 10 hours of work; the belts lengthen • restore the regular tension and then check every 50 work hours. • worn belts; replace them.
Irregular cutting of the shredded product and uneven distribution	<p>Excessive residues accumulated under the frame, clean the flail mower.</p> <ul style="list-style-type: none"> • worn knives or hammers; replace them. • worn counter knife; have it restored at specialist service centres. • PTO too slow; ideal PTO speed 450/540 rpm. • overly high forward speed; slow down.
Roller blocked	<p>The scraper is compressed on the roller; adjust the height.</p> <ul style="list-style-type: none"> • place the scraper at a distance of approximately 2 mm from the roller • bearings blocked; replace them.
Oil leakage from cylinder or pipes	<ul style="list-style-type: none"> • Replace the seals.



11. PUTTING THE FLAIL MOWER INTO REST MODE

At the end of the season or if a long period of non-use is envisaged, the following are advisable:

- Wash the machine thoroughly and dry it.
- Carefully check the entire flail mower and replace any damaged or worn parts if necessary.
- Check the tightness of the screws and nuts and, if necessary, re-tension in particular the screws of the knives or hammers.
- Remove the belts.
- Lubricate the unpainted parts.
- Perform thorough greasing and finally protect all the equipment with a synthetic cloth and place it in a dry environment.

If these operations are performed with care, the advantage will be for the user as they will find the equipment in a perfect condition upon resuming work.

12. DISMANTLING

When the owner of the machine decides never to use it again, it is advisable to render harmless the parts of the machine that are more dangerous and that can cause environmental pollution, for example:

- Remove all the lubricating oil present in the machine and take it to the collection centres authorised by the laws and regulations in force.
- Scrape all metal parts and place them with authorised collection centres.

13. TECHNICAL ASSISTANCE

The user is never authorised to intervene on the machine with the exception of maintenance operations as provided for in the use and maintenance manual.

For any repairs, the user must only contact an authorised service centre.



14. WARRANTY

The warranty has a duration of 1 year from the date of delivery. Check upon delivery that the equipment has not been damaged during transportation and that the accessories are complete.

Carefully check that the protections are complete and that they are not damaged.

If these parts are damaged or are missing for some reason, do not operate the machine.

Any complaints must be submitted in writing to the retailer within 8 days.

The buyer may only assert their rights under warranty if they have complied with the conditions relating to the presentation of the warranty.



CAUTION!

Sicma s.r.l. will supply spare parts found to be defective during the warranty period; it will not reimburse the costs of transportation and labour for the replacement of parts.

14.1 Warranty expiry

The warranty is not recognised in the following cases:

- Operator manoeuvre error
- Insufficient maintenance (for example, absence of lubrication of the cardan shaft).
- The machine is used for purposes not intended for its function.
- If, through repairs not carried out by Sicma s.r.l. or by the authorised dealer, or due to the installation of non-original parts, the machine should undergo changes that cause damage to normal operation.
- If operations not relating to the use and maintenance manual have been carried out.





Sicma S.p.A

Contrada Cerreto, 39

66010 Miglianico (Chieti) – Italy

® Tel. +39 0871 958 41 – www.sicma.it