

CE

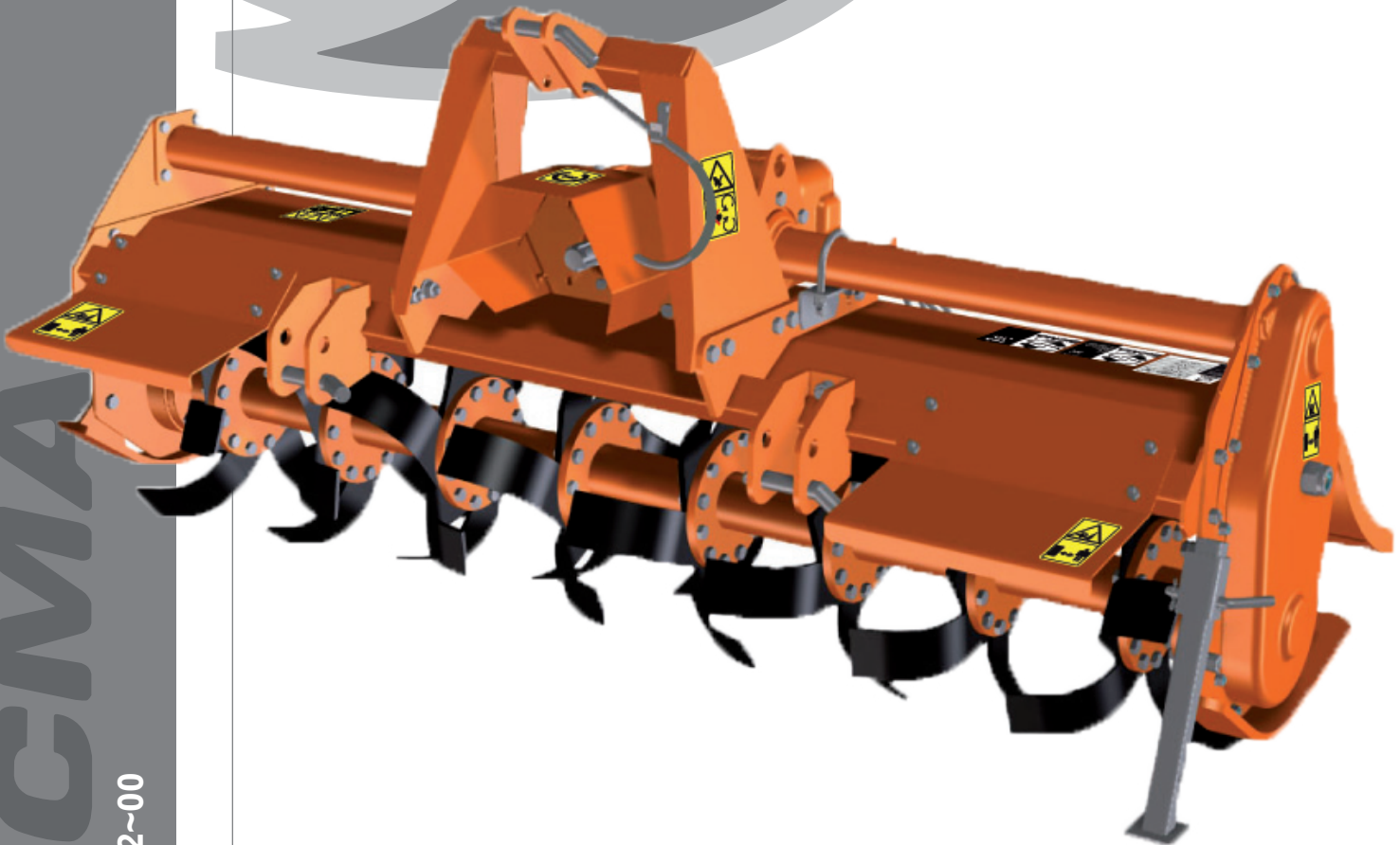

Tiller

RC 085•105•125•135•165•185•205

USE AND MAINTENANCE MANUAL

® 903879002~00

TRANSLATION OF ORIGINAL INSTRUCTIONS



MADE IN ITALY



INDICE

1.	INTRODUCTION	5
1.1	SOME NOTES REGARDING THE USER MANUAL	5
1.2	DECLARATION OF CONFORMITY	6
1.3	LIST OF RESIDUAL RISKS	7
1.4	DELIVERY LETTER	8
1.5	TILLER IDENTIFICATION AND MANUAL CODE	9
1.6	GENERAL DELIVERY NOTES	10
1.7	DECLARED USE	11
1.8	TILLER COMPOSITION	12
1.9	HOES SET-UP	12
2.	SAFETY	13
2.1	DEFINITIONS (UNI EN ISO 12100-1:2009)	13
2.2	CONVENTIONAL SYMBOLS	13
2.3	SAFETY PRESCRIPTIONS	14
2.4	OPERATOR REQUISITES	14
2.5	CLOTHING AND PPE	15
2.6	MACHINE USE	15
2.7	SAFETY DEVICES	16
2.8	REASONABLY PREDICTABLE INCORRECT USE	16
2.9	ZERO ENERGY STATE	16
2.10	POSITION OF PICTOGRAMS ON THE MACHINE	17
3.	UNLOADING AND UNPACKING THE TILLER	19
3.1	TILLER PROTECTED BY HEAT-SHRINKABLE FILM	19
3.2	TILLER IN WOODEN CRATE	20
4.	TECHNICAL FEATURES	22
5.	START-UP	22
5.1	3-POINT HITCH CONNECTION	23
5.2	CARDAN SHAFT CONNECTION	24
5.3	CHECK THE STABILITY OF THE TRACTOR-TILLER COMPLEX.	25
5.4	ROAD TRANSPORT	25
6.	ADJUSTMENTS	26
6.1	ROTOR ROTATION SPEED GEAR	26
6.2	CLUTCH ADJUSTMENT	26
6.3	WORKING HEIGHT ADJUSTMENT	27
6.4	MACHINING	27
6.5	PREVENTIVE MAINTENANCE	28
7.	STOPS	29
8.	ROUTINE MAINTENANCE	30
8.1	CONTROL AND REPLACEMENT OF THE OIL IN THE GEARBOX UNIT	32
8.2	CONTROL AND REPLACEMENT OF THE OIL IN THE LATERAL DRIVE SUMP	33
8.3	GREASING THE ROTOR SUPPORT	33
8.4	HOES REPLACEMENT	34
8.5	CARDAN SHAFT	34
9.	CLEANING	34
10.	STORAGE AND WINTERING	35
11.	SCRAPPING	35



12.	QUICK CONSULTATION TABLES	36
12.1	COUPLING TORQUE TABLE	36
12.2	TROUBLESHOOTING TABLE	37
12.3	MAINTENANCE TABLE	38
13.	SPARE PARTS	39
14.	WARRANTY	39



Congratulations on your purchase of the **RC Tiller**

The RC Tiller is manufactured by SICMA S.p.A, which has been producing agricultural machines for over 40 years.

The RC Tiller has all safety and quality requisites required for this type of equipment.

Remember that to obtain the best performance and make the best of the production features, it is necessary to know the instructions and information contained in this manual and follow the same.

1. INTRODUCTION

1.1 SOME NOTES REGARDING THE USER MANUAL

Remember that the USER MANUAL is not an accessory of the tiller but is an INTEGRAL part and a SAFETY MEASURE (EN 12100-1).

For this reason:

- kept in a good state;
- it must be kept near to the equipment;
- pass it to any operator user, maintenance technician, handler or successive owner.

In this way, the tiller can be used in the best way for all functions for which it has been manufactured and in maximum safety.

The manual must not be damaged, it must remain integral (do not rip the sheets), must be kept away from humidity and heat. During consultation it must not be covered in grease or its legibility deteriorated.

If this manual is lost or damaged, ask for a copy from the Manufacturer or nearest Dealer.

To ease consultation, the manual has been divided into parts so that every phase is described well.

With these arrangements, SICMA intends to unmistakably call the operator's attention to the dangerous situations that may occur.



1.2 DECLARATION OF CONFORMITY

The machine is delivered accompanied by the following Declaration of Conformity.

EC DECLARATION OF CONFORMITY

The company

Sicma s.p.a. - C.da Cerreto, 39 - 66010 Miglianico (Ch) - Italy
Tel.: +39 0871 95841 - Fax: +39 0871 950295
e-mail: info@sicma.it - http://www.sicma.it

hereby declares that:

product: TILLER
model: RC
serial number:

complies with the essential requirements for safety and health of Directive 2006/42/CE.

To fulfil the above mentioned Directive have been applied the following harmonised standards:
-UNI EN ISO 4254-1:2010, EN ISO 4254-5:2009, UNI EN ISO 12100-1:2009, UNI EN ISO 12100-2:2009

and the technical standards and specifications
- ISO 11684:1995, ISO 13852:1996, UNI 9456:1989.

The person authorised to compile the technical file is Mr. Lorenzo Aurora



Miglianico, 15-03-2011

Lorenzo Aurora
AMMINISTRATORE UNICO



1.3 LIST OF RESIDUAL RISKS

Even though SICMA has done everything possible to be in line with state-of-the-art safety and in compliance with all Directives, Laws and Standards in force, some residual risks still exist:

- CUT/CRUSHING HAZARD DUE TO CONTACT WITH TOOLS (rotor)
- ENTANGLEMENT/Dragging HAZARD (rotor and Cardan shaft)
- OVERTURNING/CRUSHING HAZARD (tiller)
- BURNS HAZARD (gearbox)
- CUT/SHEARING HAZARD (rear covers)



Therefore, anyone using the machine or performing maintenance on the same, must be trained and aware of the fact that dangers exist and in spite the use of protections to reduce them, it is not possible to eliminate them totally.

The staff assigned to these operations must always have the use and maintenance manual available for consultation.

The use and maintenance manual states all indications requested from point 1.7.4 (User instructions) of Attachment 1 of the Machinery Directive and specific request is made to comply with the prescriptions, so as not to cause accidents that can injure persons.

1.4 DELIVERY LETTER

The tiller has been manufactured in compliance with the 2006/42/CE Directive, and has been designed in compliance with the guide lines of the Technical Standards relative to the tillers, specifically UNI EN ISO 4254-1:2010 and UNI EN ISO 4254-5:2009.

Therefore, the machine does not represent a danger for the operator if used according to the instructions in this manual and on condition that the safety devices are kept constantly efficient.

This form attests receipt of the tiller:

- the safety devices are present.
- this manual has been delivered



SICMA INFORMS THAT ANY MODIFICATION OR TAMPERING OF THE TILLER OR ANY OPERATION PERFORMED IN DISAGREEMENT WITH THAT WRITTEN IN THIS MANUAL, ESPECIALLY FAILURE TO COMPLY WITH THE SAFETY PROVISIONS, AS WELL AS MAKING THE WARRANTY NULL AND VOID, RELIEVES SICMA FROM ANY LIABILITY FOR DAMAGE TO OBJECTS AND INJURY TO PERSONS.

Some of the devices described in this manual may not be present on your machine, depending on the chosen set-up and the market of destination.

It must be remembered that all technical values refer to the standard tiller (see Chap. 4 "Technical Features") and the drawings and any other document delivered along with the tiller are the property of SICMA, which reserves all rights and reminds that they cannot be made available to third parties without its written approval.

Therefore, any reproduction, even partial, of the text and illustrations is prohibited.

The information, descriptions and illustrations contained in this manual reflect the state of the art of the machine at the moment it was put on the market.

The Manufacturer reserves the right, at any time, to apply modifications to the machinery for technical or commercial reasons. Such modifications do not oblige the Manufacturer to intervene on machines sold up until that moment, nor to consider this publication inadequate.

Any integration that the Manufacturer will consider opportune to supply later on must be preserved together with the manual and be considered an integral part of the same.



1.5 TILLER IDENTIFICATION AND MANUAL CODE

For any after-sales requests or information regarding the tiller, contact SICMA or its after-sales centres always stating the model and the serial number stated on the plate.

The identification code of this manual is written on the cover. Write the number in a different place so that if this manual is lost or damaged, another copy can be requested from SICMA or the nearest dealer by also stating the serial number visible in the marking.

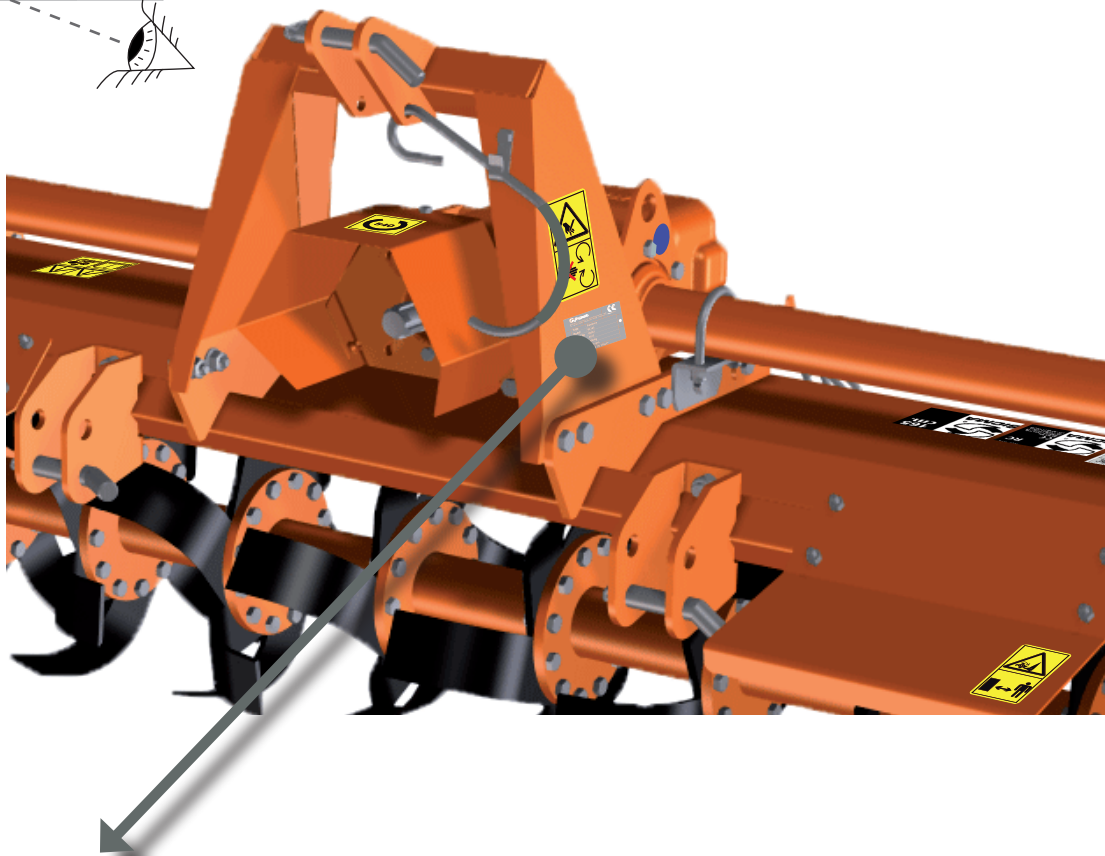

SICMA 

SICMA SPA - C.da Cerreto, 39 - 66100 Miglianico (Ch) - Italy
Tel.: +39 0871 95841 Fax: +39 0871 950295 - info@sicma.it - www.sicma.it

Type	Tiller
Model	RC165
Serial No	00561
Year	2013
Mass	290 Kg
Input	540 rpm

MADE IN ITALY



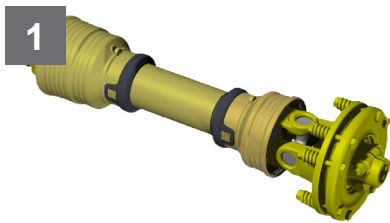

1.6 GENERAL DELIVERY NOTES

The tiller and its parts and/or accessories are normally delivered by lorry or container.

On receipt of the machine, check that:

- the supply corresponds with the order specifications (see transport document or packing-list)
- there is no damage to the tiller or accessories
- in the event of damage or missing pieces, inform the SICMA or its area representatives, the carrier or its insurance immediately in detail and/or with photos
- the spare parts or equipment supplied are sometimes in separate containers.

The machine is delivered by SICMA equipped with the following supplies:

- 1 - CARDAN SHAFT
- 2 - TILLER USE AND MAINTENANCE MANUAL
- 3 - CARDAN SHAFT USE AND MAINTENANCE MANUAL
- 4 - CE DECLARATION OF CONFORMITY



1.7 DECLARED USE

The RC Tiller has been designed expressly to work land and has been developed with the sole purpose of loosening, turning and oxygenating the land in order to prepare it for sowing.

It has been manufactured to be coupled to tractors that can support the weight of the tiller, with hydraulic lifting device and universal three point hitch and to be activated by the tractor PTO via Cardan transmission.

USE ENVIRONMENT

The tiller works:

- in open fields, on non friable land, not excessively stony with a maximum gradient of 3°
- in environments with a temperature from 0° ÷ 50° C.

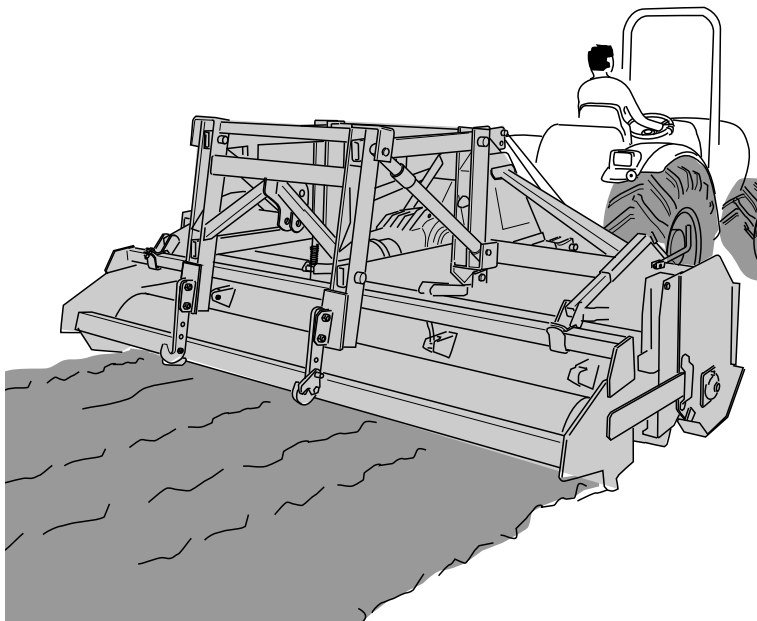

IMPROPER USE

Any use different to that declared is to be considered improper.

Sometimes the operator uses the tiller incorrectly, below find some examples the must NOT BE PERFORMED.

The operator must not:

- connect the tiller to a Cardan shaft with greater or smaller power
- work in reverse gear compressing the earth with hood press
- couple the tiller to vehicles of unsuitable power or weight
- assemble the tiller without securing the rebound tie rods of the three-point hitch of the tractor's elevator
- lift the equipment when the PTO is rotating
- make curves or reverse with the tiller lowered

Remember that the tiller is developed only with the purpose of the declared use.

Any other use is to be considered improper.

1.8 TILLER COMPOSITION

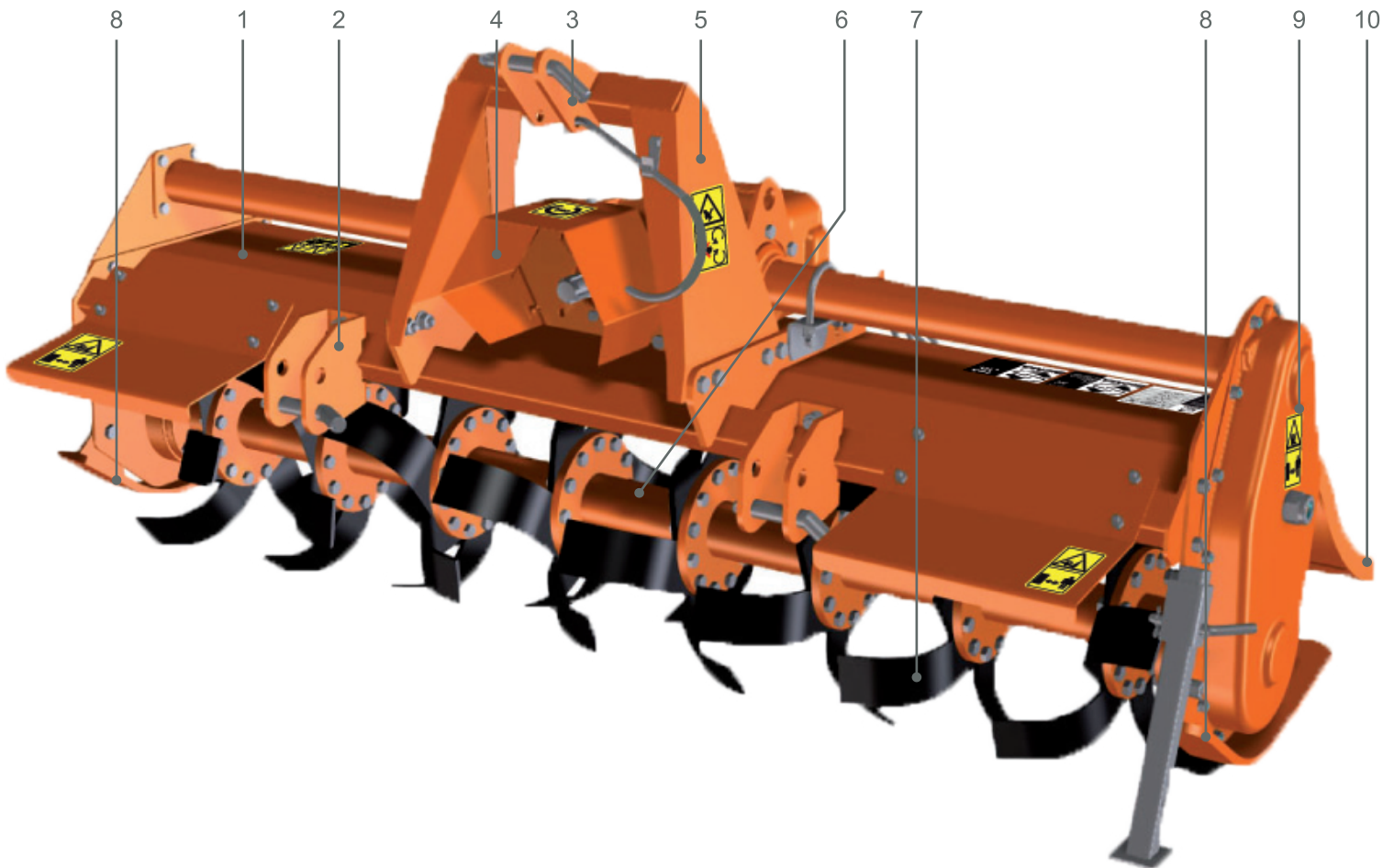

- 1 Chassis
- 2 Lower 3-point hitch
- 3 Upper 3-point hitch
- 4 Cardan shaft protection
- 5 3-point hitch mast
- 6 Rotor
- 7 Hoes
- 8 Side skids
- 9 Drive sump
- 10 Bonnet

1.9 HOES SET-UP

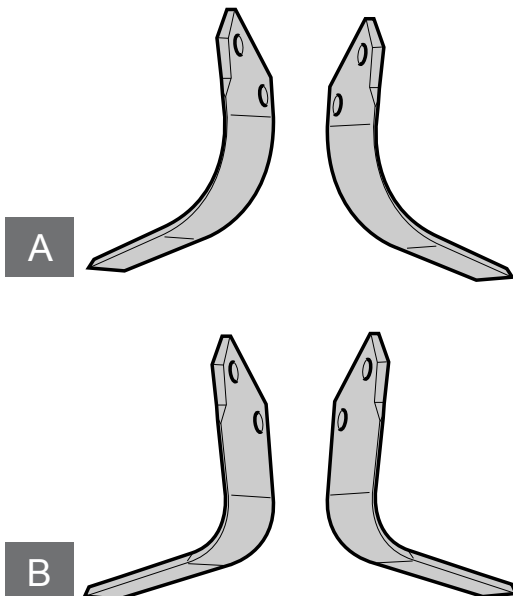

Rif.	Description	Quantity							
		RC085	RC105	RC125	RC135	RC145	RC165	RC185	RC205
A	Curved hoes kit code 4821401	8	10	12	14	14	16	18	20
B	Square hoes kit code 4821402	8	10	12	14	14	16	18	20

2. SAFETY

During consultation of this use and maintenance manual and on the equipment itself, it is possible to find several symbols whose meanings are illustrated below.

2.1 DEFINITIONS (UNI EN ISO 12100-1:2009)

DANGER:

A potential source of physical injury or damage to health.

DANGEROUS AREA:

Any area within and/or in proximity of a machine in which the presence of a person constitutes a risk for the safety and health of the same.

The dangerous area is the area around the machine (attached to the tractor) up to a distance of 1 metre.

CRITICAL AREA

The critical area is that between the tractor and the equipment (Cardan shaft area).

EXPOSED PERSON:

any person that is totally or partially inside a dangerous area.

2.2 CONVENTIONAL SYMBOLS



ATTENTION GENERAL HAZARD

Informs the staff assigned that the operation described has the risk of physical injury if not performed with respect to the Safety Standards.



NOTE

Informs the staff assigned of information whose content is of relevant consideration and importance.



WARNING

Informs the staff assigned of information whose content can cause slight injury to persons or damage to the machine if not respected.



MACHINE OPERATOR OR DRIVER

Identifies qualified staff, i.e. with specific skills, as the operations are completely manual, therefore refer to the preparation and sensitivity of the machine driver to obtain the best qualitative results. It is therefore prohibited for the operator to perform operations that are the responsibility of the maintenance technician.



MECHANICAL MAINTENANCE STAFF

Qualified technician able to intervene on mechanical parts in order to make all regulations, maintenance interventions and repairs necessary.



EXTRAORDINARY INTERVENTIONS

Any maintenance interventions highlighted by the symbol at the side are to be requested from the manufacturer or authorised workshops.



PERSONAL PROTECTIONS (PPE)

The presence of one of the symbols at the side imposes the use of the corresponding PPE by the operator, as the risk of accident is implicit.



RECOMMENDATION

It refers to a work mode experimented on field, knowing well that every operator will develop his own way of operating.



2.3 SAFETY PRESCRIPTIONS

Even though SICMA has applied all possible safety devices on the equipment, it must be remembered that it can be dangerous for health if not used correctly. It is therefore advised to read and comply with the safety prescriptions listed below.

Before using the equipment, all operators **MUST** have read and understood the safety prescriptions and the entire user manual.

- The machine is not suitable to be used in other sectors than in agriculture.
- Any use different to that specified is to be considered improper.
- The manual must always be on hand, in a way to consult it when necessary. If it should be lost or damaged, request a replacement copy from SICMA.
- Do not climb onto, sit on or rest on the equipment for any reason, whether it is on or in the zero energy state (see par. 2.9).

2.4 OPERATOR REQUISITES

- The machine must only be used by one operator driving the tractor.
- The machine must be used exclusively by authorised, instructed and trained operators. The operator, besides having read and understood the instructions contained in this manual, must also be sufficiently prepared on the proper use of the machine and must have a driving license. The operator must contact the dealer or the manufacturer if in doubt regarding use of the machine or interpretation of this manual.
- The operator must make sure that no person or animal stops within the radius of action of the same during machine functioning. Never activate the machine near to persons standing or transiting within the radius of action of the machine.
- Do not use the machine if you are tired, ill or under the effect of alcohol, medicines or drugs.
- The correct operator position is in the tractor driving seat. From this position he must also control that there are no persons exposed in the dangerous area in the work phase.

2.5 CLOTHING AND PPE



- Staff must use the safety supplies and PPE during use and maintenance of the vehicle.

The correct clothing to be worn during maintenance operations and use of the tiller is:

- gloves
- accident-prevention shoes or boots with steel toe-cap
- glasses
- overall with elastic on the wrists, ankles and around the waist.

Moreover:

- given that the machine can generate emissions of dust during working, if the tractor does not have a closed cab, the operator must wear an anti-dust mask (especially on dry and dusty land)
- if the tractor does not have a sound-proof cab, the operator must wear hearing protections (especially on stony land)
- the operator assigned to the machine must not wear items of clothing that can cause entanglement (scarves, belts, wide sleeves, etc.)

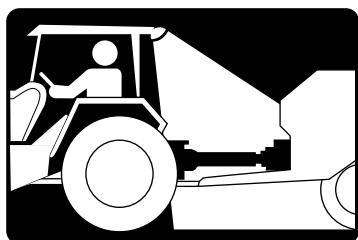
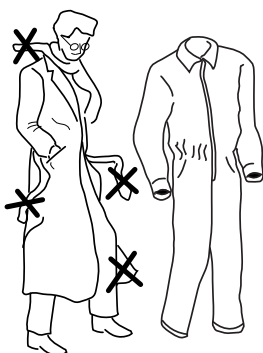

2.6 MACHINE USE

- The machine is usually used during the day. If night-time use is exceptionally requested or use in conditions of reduced visibility, a tractor lighting system or an auxiliary lighting system must be used.
- Any arbitrary modification made on this machine lifts Sicma from any responsibility for damage or injuries that could result to operators, third parties or to objects.
- Check the machine thoroughly before each start-up.
- Check the tightness of all bolts daily (consult torque table par. 12.1), tighten them if necessary and also check the metal structures and repair, if required.
- Check that the retainer chains snap hooks of the Cardan shaft protection are hooked in the appropriate slot, in a way that the plastic protection remains at a standstill and does not turn with the Cardan shaft itself.
- Before getting out of the tractor and before any maintenance operation, activate the parking brake, turn the engine off, remove the ignition key from the dashboard and keep it.
- The hoes rotate rapidly when the machine is functioning: stay at a safe distance to prevent accidental contact with moving tools or with thrown objects.



2.7 SAFETY DEVICES

- Before using the machine, make sure that all safety devices are properly in place and in good conditions. If there are failures or damage to the guards, replace them immediately.
- Do not tamper with or bypass safety devices for any reason. After every cleaning and maintenance intervention, all of the safety devices must be restored and/or all protection guards closed. Check also that tools, cloths or various materials do not remain in the drive compartments.
- The signs applied to the machine supply a series of important indications: compliance with the same is for your safety.
- Make sure the safety pictograms are in good conditions. If the pictograms has deteriorated, they must be replaced with other original versions requested from the manufacturer and placed in the position indicated by the use and maintenance manual.

2.8 REASONABLY PREDICTABLE INCORRECT USE

The operator must not:

- connect the tiller to a Cardan shaft with greater or smaller power
- modify the calibration of any safety element in a way to exclude its effectiveness (clutch bolts tightened completely)
- work in reverse gear compressing the earth with hood press
- make modifications to the equipment that could jeopardise safety
- perform makeshift repairs in order to work.

Moreover, it is prohibited to:

- couple the tiller to vehicles of unsuitable power or weight
- assemble the machine without securing the rebound tie rods of the three-point hitch of the tractor's elevator
- lift the equipment when the PTO is rotating
- tamper with hydraulic circuits
- use the machine to transport and/or to lift persons, animals or objects
- work on ground with gradient over 3°.

Sicma declines any liability for accidents deriving from the failure to comply with the prescriptions indicated below.

Given the particular stress to which the equipment is subjected and for safety reasons, if pieces are replaced, only use original spare parts.

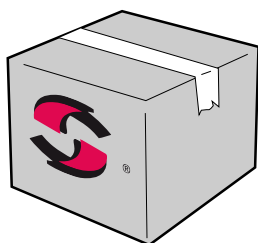

2.9 ZERO ENERGY STATE

The "zero energy state" is defined as the state in which the tiller is to be taken before performing any cleaning, lubrication and maintenance operation. Perform the following operations to take the tiller to the "zero energy state":



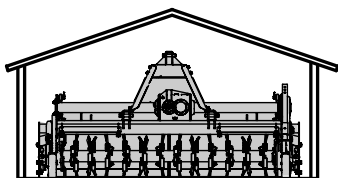



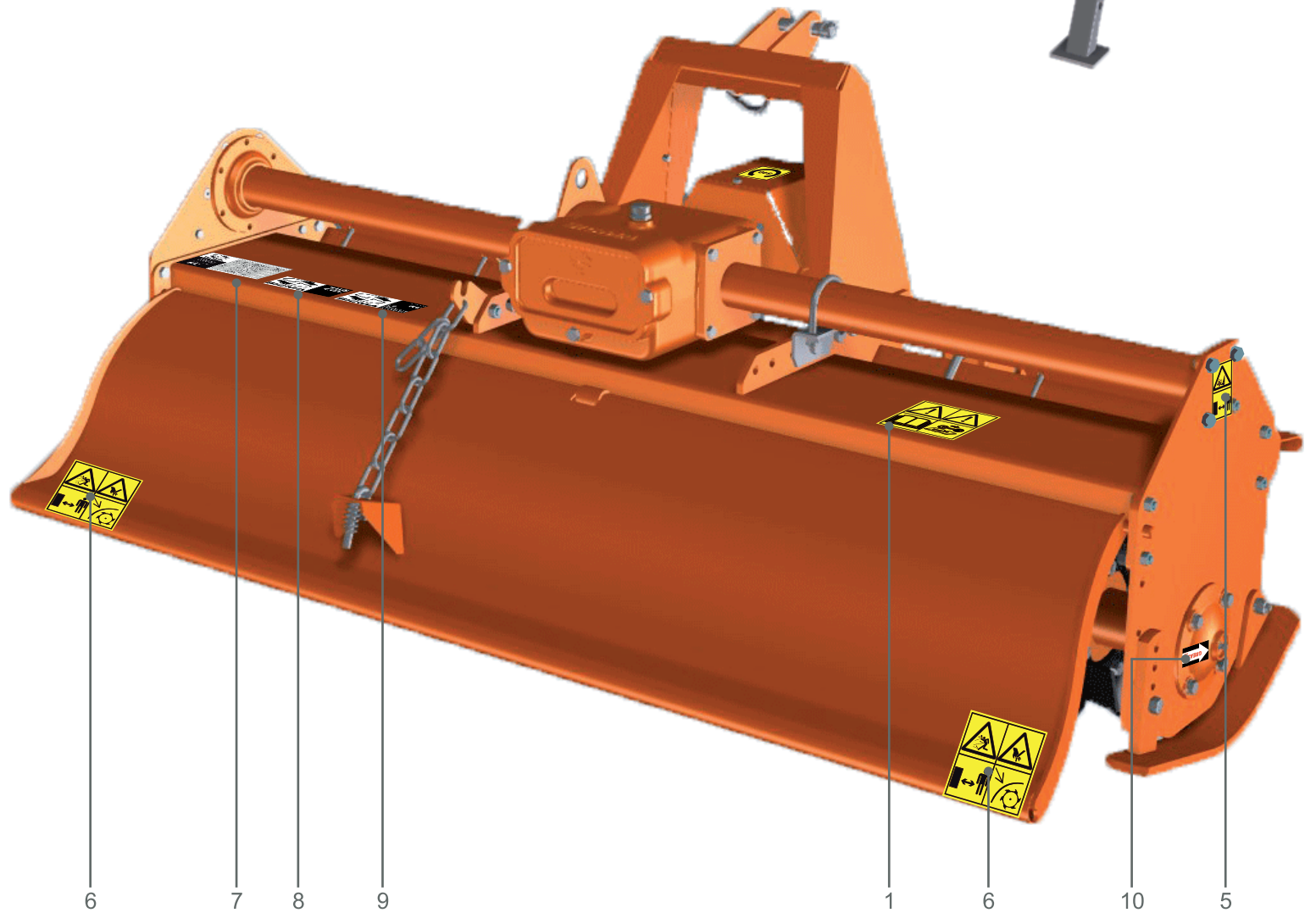
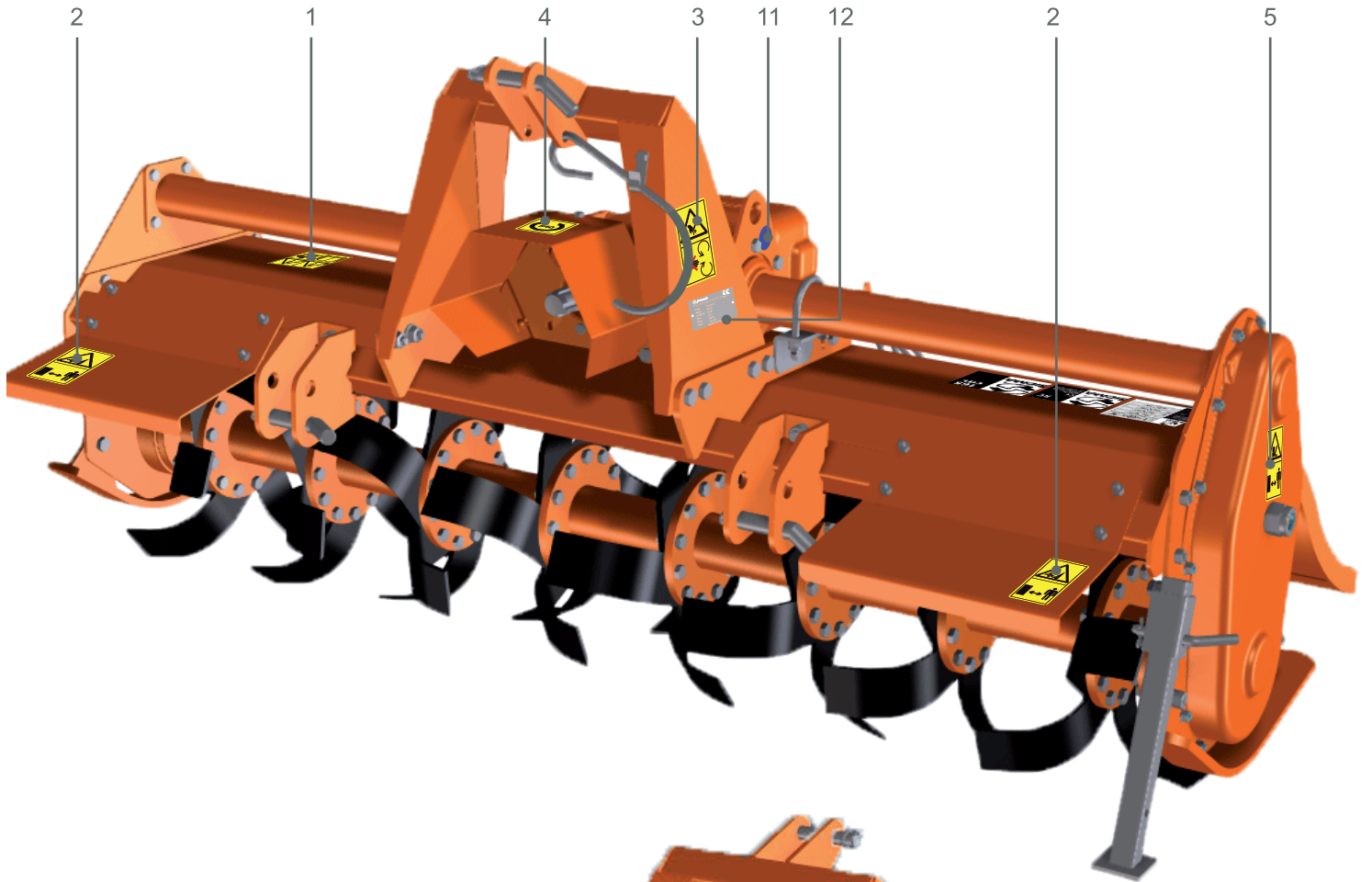

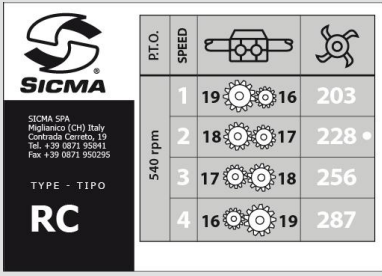

- position the tiller on stable, flat land with maximum gradient of 3°
- disable the PTO from the tractor
- engage the tractor hand brake
- switch the tractor off, remove the key and keep it
- get off the tractor and disconnect the Cardan shaft from the PTO tractor.
- position the outrigger in the stop position
- disconnect the 3-point hitch



2.10 POSITION OF PICTOGRAMS ON THE MACHINE



SAFETY PICTOGRAMS

<p>1</p>  <p>4781029 ATTENTION Read all instructions and safety rules carefully before using the machine. Stop engine and remove key before starting maintenance or repairs.</p>	<p>7</p>  <p>4787902 GEAR INFORMATION</p>
<p>2</p>  <p>4781011 FOOT INJURY HAZARD Rotating tools: keep a safety distance from the machine.</p>	<p>8</p>  <p>4787901 MACHINE INFO</p>
<p>3</p>  <p>4781013 HAND INJURY HAZARD Rotating parts: keep a safety distance from the machine.</p>	<p>9</p>  <p>000-085; 000-105; 000-125; 000-135; 000-145; 000-165; 000-185; 000-205 LENGTH INFO</p>
<p>4</p>  <p>4781010 INPUT 540 RPM Use of a 540 rpm power takeoff.</p>	<p>10</p>  <p>4781009 GREASE Indication of greasing point</p>
<p>5</p>  <p>4781012 FOOT INJURY HAZARD Keep at a safe distance from the machine.</p>	<p>11</p>  <p>4781031 HITCH POINT For lifting the machine.</p>
<p>6</p>  <p>4781019 THROWN OBJECTS ON ENTIRE BODY Keep at a safe distance from the machine. Hand injury hazard: do not open or remove safety guards while the machine is operating.</p>	<p>12</p>  <p>4780001 CE MARKING PLATE</p>



3. UNLOADING AND UNPACKING THE TILLER



ATTENTION CRUSHING HAZARD



ATTENTION GENERIC HAZARD



ATTENTION CRUSHING AND ENTRAPMENT HAZARD



ATTENTION SWINGING AND CRUSHING HAZARD

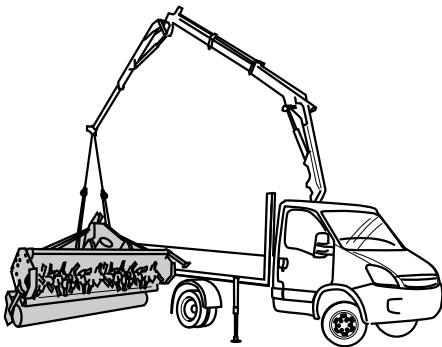

ATTENTION

Qualified staff that has read and understood the safety prescriptions must unload the tiller from the lorry and handle the equipment in the work place.

A person in charge of operations must always be present during loading and unloading. In all cases, make sure that there are no persons, animals or objects in the unload area and behave as described in this manual.

The tiller is normally transported on a lorry, sometimes without packaging, sometimes protected by heat shrinkable film and other times in wooden cases.

ATTENTION

Read and understand the "Safety prescriptions" part before starting to transport and unpack the tiller.

3.1 TILLER PROTECTED BY HEAT-SHRINKABLE FILM

NOTE

Before starting to unload the equipment from the lorry, read the entire sequence in a way to be prepared for every inconvenience in time.

Release the tiller from any fixing devices used to fasten it to the means of transport.

ATTENTION

Tiller unloading operations must be performed very slowly and the operator must make sure that there are no persons, animals and objects exposed in the unloading area.

ATTENTION

Before starting lifting

- check the good state of preservation of the ropes or chains used to lift the machine
- use ropes/chains with suitable capacity. Keep in mind that each individual rope/chain must be able to lift the weight of the tiller (see Part 3 "technical features")
- make sure that the hook bolts are fastened well
- in the event of chains with shorteners, make sure that this are also fastened correctly.

After having fastened the tiller with the ropes and/or chains, lift the equipment by a few centimetres to see if it is lifted parallel to the ground, otherwise adjust the length of the ropes/chains.

ATTENTION

Lift the tiller from the deck of the means of transport to a height of about 30 cm. unless obstacles are present, so that it does not swing. Position the tiller on the ground in proximity of the tractor.

Remove chains or ropes.

Once on the ground, unpack the equipment as described below.



ATTENTION CUTTING HAZARD

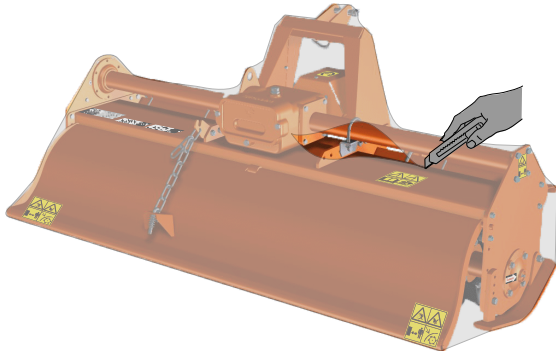

ATTENTION CUTTING HAZARD

If the tiller arrives wrapped in protective film, wear suitable gloves and use a cutter to remove the cellophane, paying attention not to injure the hands or damage the tiller itself.

ATTENTION POLLUTION HAZARD

Once the tiller has been unpacked, do not disperse the casing in the environment but contact a specialised agency for its withdrawal. Check the transport document or packing-list supplied and, if necessary, act as described in chapter 1 "General Delivery Notes".



3.2 TILLER IN WOODEN CRATE

NOTE

Before starting to unload the equipment from the lorry, read the entire sequence in a way to be prepared for every inconvenience in time.

If the tiller is contained inside a wooden crate, use a fork-lift truck with suitable capacity to unload it (consult technical features table to see tiller weight) or use the lorry's lifting arm.



ATTENTION CRUSHING AND ENTRAPMENT HAZARD

ATTENTION

Tiller unloading operations must be performed very slowly and the operator must make sure that there are no persons, animals and objects exposed in the unloading area.

Insert the lifting truck forks into the appropriate spaces under the crate. Lift the crate from the deck of the means of transport to a height of about 30 cm. unless obstacles are present.

Position the crate on the ground in proximity of the tractor.

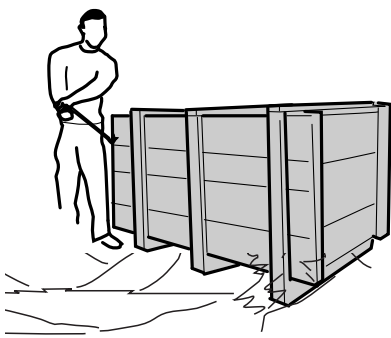

Wear gloves and using a suitable tool, remove the cover from the wooden case.

Use a fork lift truck with suitable capacity for the weight of the tiller (see part 4 "Technical features").

After having fastened the tiller with the ropes and/or chains, lift the equipment by a few centimetres to see if it is lifted parallel, otherwise adjust the length of the ropes/chains.

Use ropes/chains with suitable capacity to lift the tiller.

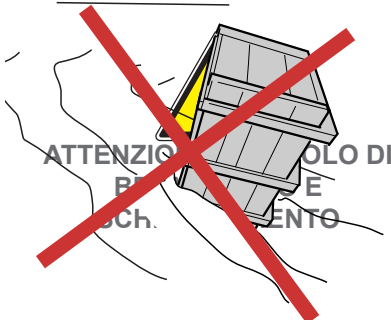

Lift the tiller a max. of 30 cm from the crate and position it near to the tractor.

ATTENTION POLLUTION HAZARD

Once the tiller has been unpacked, do not disperse the packaging in the



environment but contact a specialised agency for its withdrawal or keep it for other transports. Check the transport document or packing-list supplied and, if necessary, act as described in chapter 1 "General Delivery Notes".



**ATTENTION OVERTURNING
HAZARD**

ATTENTION

Remember that no matter how stable the equipment, during successive transport operations, it must ALWAYS:

- be well fastened to the lorry, paying attention not to crush any hydraulic pipes
- be positioned in the centre of the lorry and not at the edges. In this way, overturning dangers are prevented, due to curves or uneven roads.

4. TECHNICAL FEATURES

Below find the table stating the technical features of the RC Tiller.

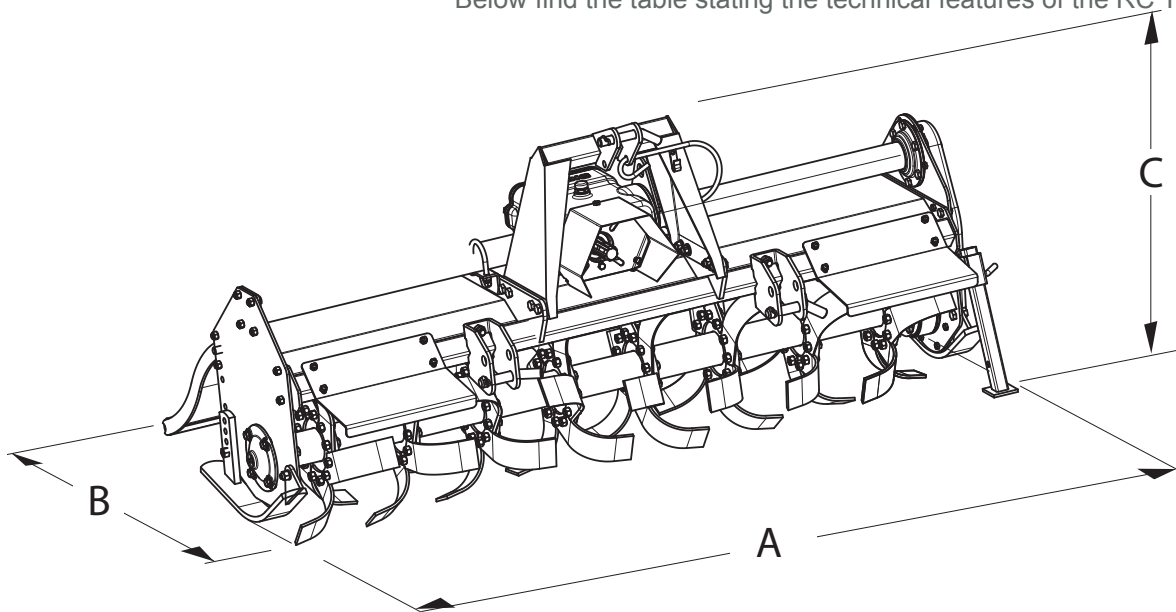

TECHNICAL FEATURES

Ref.	Description	RC							
		085	105	125	135	145	165	185	205
	Working width (mm)	850	1050	1250	1350	1450	1650	1850	2050
A	Overall width (mm)	1020	1220	1420	1520	1620	1820	2020	2220
B	Overall length (mm)	890	890	890	890	890	890	890	890
C	Height (mm)	810	810	810	810	810	810	810	810
	Mass – Weight (Kg)	205	225	245	265	285	305	325	345
	Number of revs.(rpm)	540	540	540	540	540	540	540	540
	Power requested (HP)	35 - 70	35 - 70	35 - 70	35 - 70	35 - 70	35 - 70	35 - 70	35 - 70
	Power requested (Kw)	25 - 52	25 - 52	25 - 52	25 - 52	25 - 52	25 - 52	25 - 52	25 - 52
	Curved/square hoes	16	20	24	28	28	32	36	40

5. START-UP



ATTENTION

Only qualified operators and which have read and understood the safety prescriptions can carry out the operations described below. Moreover, they must check that there are no persons, animals and objects exposed in the area where the connection is made to the tractor.

The operator and any aids must have PPE (Personal Protective Equipment) available and wear them as required.

The tiller can only be moved when connected to the tractor; scrupulously follow the instructions given below in order to perform hitching:

- 3-POINT HITCH CONNECTION TO THE TRACTOR
- CARDAN SHAFT CONNECTION

5.1 3-POINT HITCH CONNECTION

To connect the tiller to the tractor, the operator must: loosen the 3 screws indicated in the figure, which fix the Cardan protection and slide the upper one out.

Slowly approach the tractor to the tiller, position in a way that the lifting device arms of the tractor are aligned with the two lateral pins of the tiller.

Once in position, engage the hand brake, switch the engine off, remove the key and keep it and climb down from the tractor.

Check that the Cardan shaft protection is integral. If this is not the case, act accordingly consulting the relative user manual.

Proceed as follows to hitch the machine to the tractor:

- remove the split pin A of pin B on both sides
- slide the pins B out
- climb onto the tractor and switch the engine on
- disengage the brake and reverse slowly until the tractor lifting device arm joint C combines with the lower third point of the tiller D
- switch the engine off, engage the hand brake, remove the key and keep it and climb down from the tractor.
- insert the pin B into the hole of the lower third point D of the tiller and into the hole of the tractor arm joint C.
- re-insert the split pin A
- proceed in the same way with the other lower hitch.
- block the rebound tie-rods of the tractor lifting arms to prevent the machine oscillating laterally, compromising the transversal stability of the complex.

To connect the upper third point, the operator must:

- remove the split pin E of the pin F of the upper third point H of the tiller.
- slide pin F out
- release the tie-rod G of the tractor upper third point and insert it into the upper third point H of the tiller
- re-insert the pin F and the split pin E into the tiller upper third point and into the tractor tie-rod joint
- if the floating upper third point is used, make sure that it allows the machine to bend forward and backwards and that the PTO shaft is parallel to the ground.
- if the floating upper third point is not used, adjust the length of the tie-rod in a way that the PTO shaft is parallel to the ground



It is always good practice to make sure that the tiller PTO axis is parallel to the ground thus reducing the stress to a minimum on the power take-off and extending the working life of the tiller.

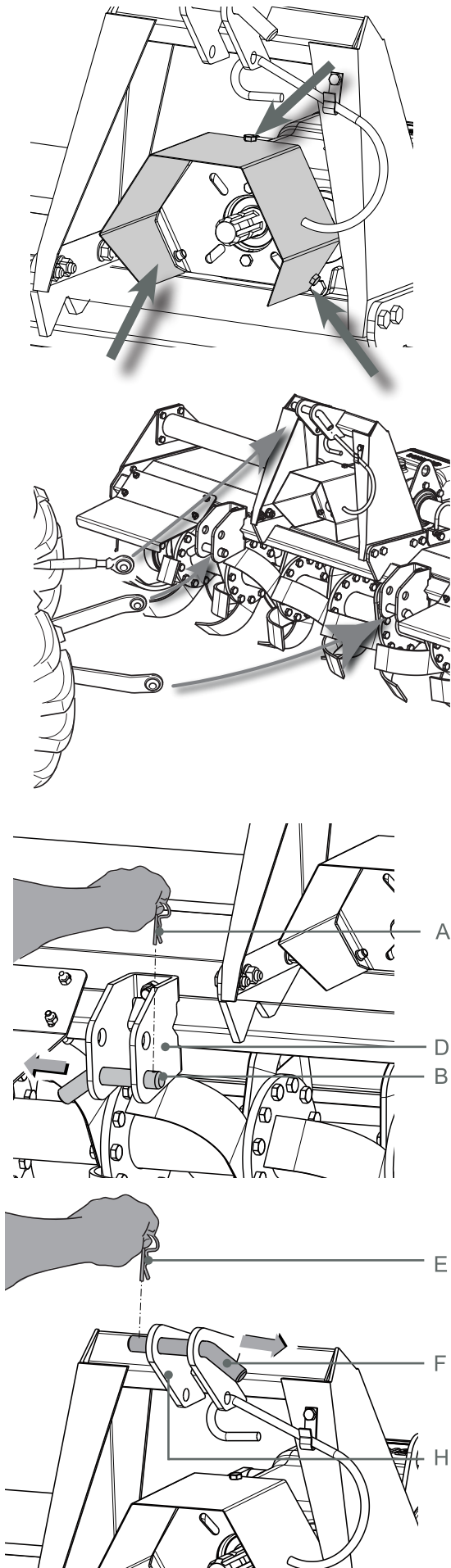
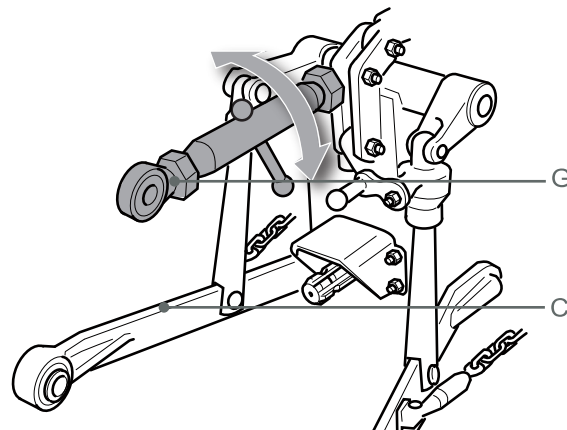



5.2 CARDAN SHAFT CONNECTION

Before assembling the Cardan shaft, the operator must:

- read the Cardan shaft and tractor manual.



INPUT 540 rpm



- check that the number of revs. and the direction of rotation of the tractor PTO correspond to those of the tiller. If the direction of rotation of the tiller does not correspond to that of the tractor, contact the dealer or an authorised workshop.

- check that the Cardan shaft minimum and maximum lengths are those required by tiller-tractor coupling. Remember that when at maximum extension, the pipes must overlap at least 1/3 of the length of the internal pipe. Moreover, in the maximum closure position of the pipes, the minimum overlapping allowed of the plastic protections must be 2 cm. in order to prevent damage to the protections and the reducer. If this is not the case, the pipes must be shortened suitably butting cutting that necessary. Consult the Cardan shaft use and maintenance manual or contact the authorised dealer.

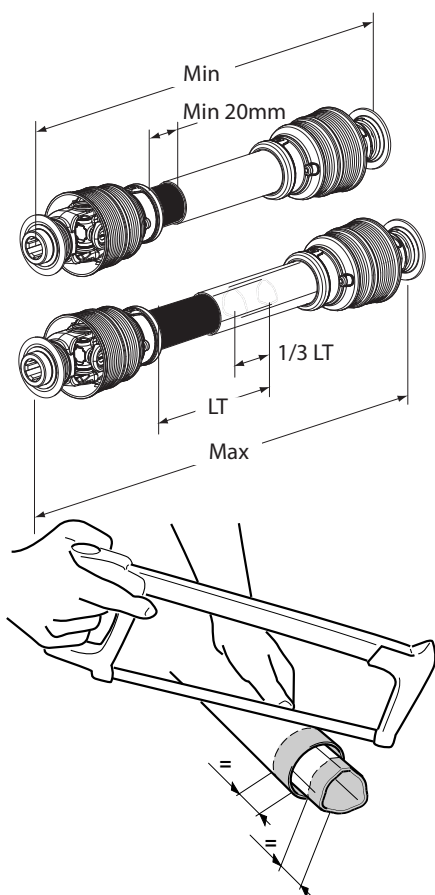

5.3 CHECK THE STABILITY OF THE TRACTOR-TILLER COMPLEX.

Tiller weight changes the stability of the tractor-tiller complex, influencing steering and braking capability. Therefore proceed at a moderate speed. In particular, remember that the front axis must always be encumbered by a weight equal to at least 20% of the total weight of the tractor-tiller complex. Check the lifting capability and tractor stability using the following formula and, if necessary, apply ballasts on the front.

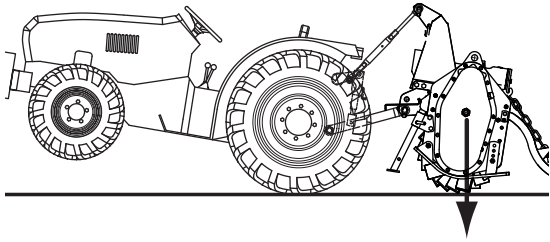

$$M \times (S1+S2) \leq 0.2 T \times i + Z \times (d+i)$$

$$M \leq 0.3T$$



i = wheel base

d = distance from the front axis from the ballasts

S1 = distance between centre of the rear axle and centre of the lower hitch points

S2 = distance between the centre of the lower hitch points and bar-centre of the tiller

T = weight of the tractor + 75Kg (operator)

Z = weight of the ballast

M = weight of the machine

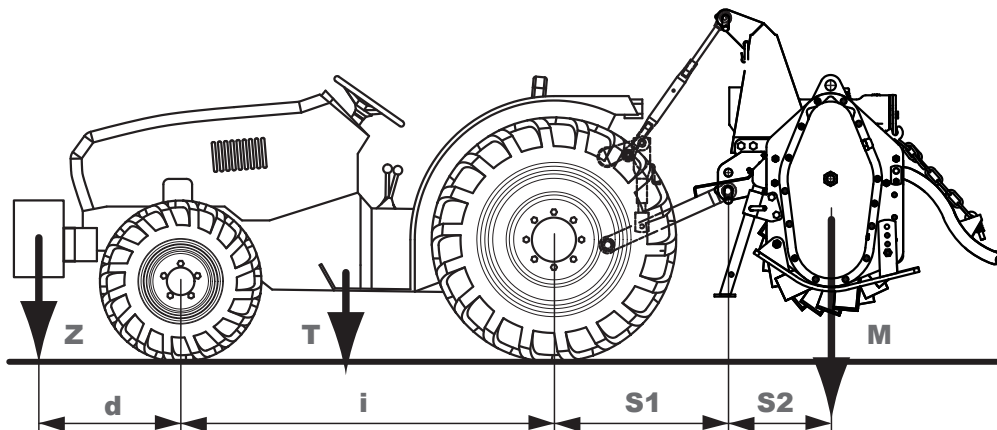

5.4 ROAD TRANSPORT

Articles 61 and 104 of the Highway Code of the Italian State prescribe that the maximum width of vehicles on roads is 2.55 metres. As a consequence, all measurements of the RC available are authorised for road transport, in compliance with the other prescriptions of the Highway Code.

If the Country of reference is not Italy, follow the Highway Code Standards of the country of use.

6. ADJUSTMENTS

6.1 ROTOR ROTATION SPEED GEAR



**ATTENTION
BURNS HAZARD**

The RC is fitted with manual gears, which allows to adapt rotor rotation speed on the basis of requirements.

To modify the rotor rotation speed, the positions of the relative straight gears, contained in the gear box, must be changed.

Before making the replacement, wait for the gearbox to cool down and wear the necessary PPD, in particular gloves; there is a hand burning hazard.

To adjust or replace the gears torque, first drain the oil from the gearbox unit (see par. 8.1).

Decide at what rotor rotation speed to work at, consulting the following table.

rpm PTO	Z1	Z2	N. revs. rotor
540	18	17	256
	17	18	228
	19	16	287
	16	19	203

(standard configuration)

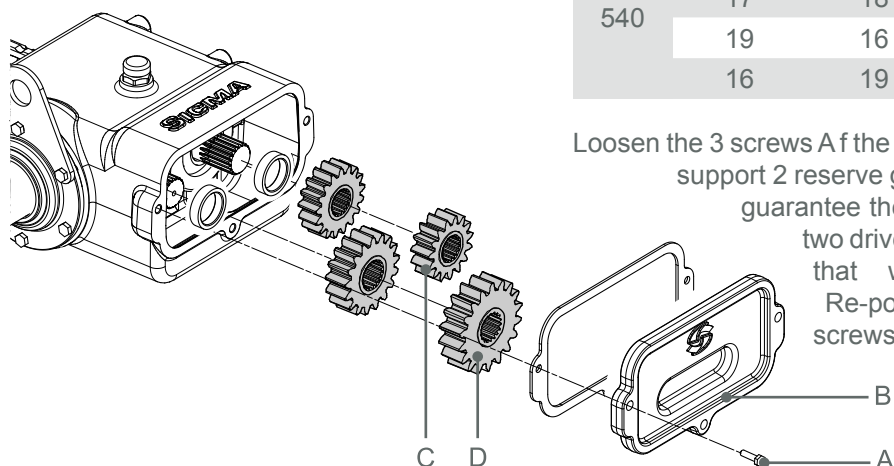

Loosen the 3 screws A of the gears support lid "B". Inside there are 2 pins that support 2 reserve gears C and D (that do not work and are used to guarantee the other speeds). The gears are flush fitted onto two drive shafts. To change the speed, invert the 2 gears that work or replace the 2 reserve gears. Re-position the gears support lid and tighten the 3 screws again.

6.2 CLUTCH ADJUSTMENT

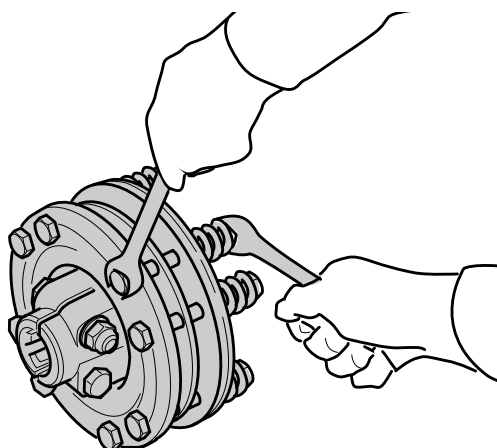

The joint and the clutch associated to the tiller are dimensioned to transmit suitable power to the machine itself. The clutch calibration value is already set in the factory, therefore it is recommended to modify it in order to prevent damage to the machine or the Cardan joint on the basis of requirements. SICMA does not respond to machine damage deriving from incorrect modification of the clutch calibration.

However, the regulation can be made if it is realised that the clutch is engaged too frequently, even though working on easy land, i.e. soft and not compact: this means that clutch calibration is too low.

The clutch associated to the Cardan Shaft is a FD1 EUROCARDAN, with standard calibration of 800 Nm. If the clutch calibration must be increased, screw the springs hold down nut by 1/4 of a turn (using two 17 mm wrenches): there will be a transmissible torque increase of about 120 Nm. Loosen the nuts if calibration is to be decreased.

In the event the clutch is not to be used for a long period, it is recommended to loosen the nuts that compress the springs in order to prevent that the disks "stick" to one another (seizure). Upon re-use of the safety device, for correct calibration carry out the following operations:

- manually tighten the nuts until they rest against the springs
- use two 17 mm wrench to loosen the nuts by 1.5 turns each.

Attention: make sure that the height of all compressed springs is the same in order to prevent clutch malfunctioning.



**ATTENTION GENERIC
HAZARD**

Warning: The clutch springs must never be tightened completely because the machine would no longer be protected against any overloads.

6.3 WORKING HEIGHT ADJUSTMENT

The tiller working height, therefore the depth at which the tools (hoes) work, depends on the adjustment of the lateral skids.

To increase the tilling depth, the height of the skids must be increased with respect to the hoes-support rotor, vice versa to decrease it.

To modify the position of the skids, after having lifted the tiller and having positioned on relative supports, operate as described:

- loosen bolt A
- loosen and remove bolt B
- therefore, turn the skid until the desired position is reached.
- re-position and tighten bolt B
- tighten bolt A
- Perform the same operation on the opposite skid, making sure that both skids are adjusted to the same height.

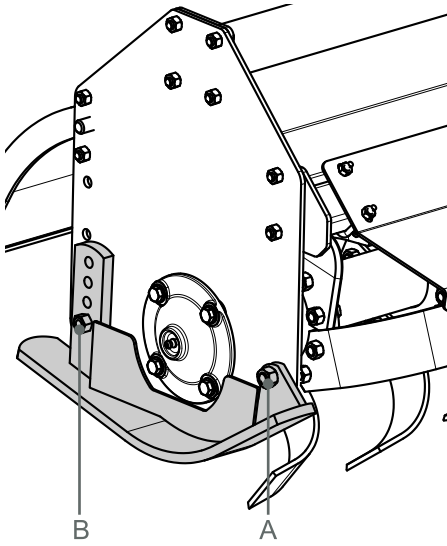

Finally check that the tiller is parallel to the ground and, if necessary, regulate its planarity by operating on the tie-rod lever of the upper 3 points hitch (see par. 5.1).

6.4 MACHINING

Once all controls and regulations have been performed, with the tractor connected to the tiller (via 3 point hitch, but with Cardan shaft disconnected), switch the tractor on and go to the work area, remembering to keep the hoes lifted so that they do not touch the ground (at least 20 cm).

The tiller must be connected to a tractor in order to operate.

The operator must refer to the tractor manual in order to manage the tiller commands.



WARNING

Before starting work, make sure that no people or animals are within the radius of action of the machine.

Make sure all equipment protections are present and efficient.

The machine must only be used by one operator positioned inside the tractor driving cab.

Make sure there are no restrictions that prevent movements. If there are restrictions, release the equipment from any fastening device.

6.5 PREVENTIVE MAINTENANCE

Before using the machine for the first time, or after a long period of inactivity, carry out the following:

- check that the machine is not damaged
- check the mechanical parts, are in good conditions and not rusted
- check the state of wear of the tools
- grease all mobile parts precisely
- check that there are no oil leaks
- check that all safety guards are properly positioned
- visually check the machine before all use. Tighten any loose bolts according to the coupling torque tables (see par. 12.1)
- check the level of oil in the gear unit box and in the lateral drive sump; top-up if necessary (see chap. 8).

Use the following lubricants for lubrication:

- oil: **AGIP-ENI BLASIA 150**
- grease: **AGIP GREASE MU EP 2**



NOTE

Before working with the equipment, read the entire sequence in a way to be prepared for every inconvenience in time. It is good practice to start the equipment in reduced normal conditions especially in cold environments, to allow the system to run-in and to prevent equipment malfunctioning.

On arrival at the work place, the operator must:

- engage the hand brake
- switch the engine off
- remove the ignition key and keep it
- get off the tractor
- check that there are no persons, animals and objects in the exposed area
- connect the Cardan shaft to the tractor PTO (see par. 5.2)

Once connected to the Cardan shaft, the operator must:

- turn the tractor engine on
- release the hand brake
- work at a maximum speed of 6 km/h reducing it to about 2 km/h if the land is difficult to work (hard, stony, etc.).

Keep the tractor engine running at a rev speed that assures the machine the power necessary for its current use.

Run a short way with the tiller working and check the quality of the work carried out. If it does not satisfy you, repeat and review the machine adjustment operations.

Never place hands and feet near to the tools-holder rotor when it is rotating (or when in zero energy state).

During functioning, the machine can project material from the rear part: make sure that animals and persons are at least 5 metres from the machine.

In the operations involving change of direction, turning and going in reverse, disengage the power take-off and lift the tiller slightly from the ground, in order to avoid structure damage.



Attention feet and hand cutting and shearing hazard



Attention thrown objects hazard

When the job has been finished, the operator must:

- engage the hand brake
- switch the engine off
- remove the ignition key and keep it
- get off the tractor
- disconnect the Cardan shaft from the tractor PTO and place it in the relevant support hook
- climb onto the tractor and release the hand brake
- switch the tractor on
- paying attention during movement that there are no exposed persons, animals or objects, take the tiller into the deposit.

Once having reached the deposit, the operator must:

- engage the hand brake
- switch the engine off
- remove the ignition key and keep it
- clean the tiller (see chap.9 “Cleaning”)
- check that there are no oil leaks, stop any leaks present (ground pollution hazard)
- check and if necessary, replace any worn parts (see chap. 8 “Maintenance”).



NOTE

If the equipment stops during working, consult par. 12.2 “Troubleshooting” Table.

7. STOPS

ATTENTION GENERAL HAZARD

Only qualified operators and which have read and understood the safety prescriptions (Chap. 2) can carry out the operations described below. Moreover, they must check that there are no persons, animals and objects exposed in the dangerous area.



Attention Hand cutting and shearing hazard

The equipment must be stopped in the following ways:

- temporary stop
- stop at the end of the day
- stop for long periods
- emergency stop

Below find the description of how to behave in each case.

TEMPORARY STOP

To stop the tiller temporarily, just deactivate the rotation of the tractor PTO by activating the relevant control in the tractor control panel.

If the operator must get off the tractor, he must:

- engage the hand brake
- switch the engine off
- remove the ignition key and keep it
- get off the tractor

STOP AT THE END OF THE DAY

- engage the hand brake
- switch the engine off
- remove the ignition key and keep it
- get off the tractor
- disconnect the Cardan shaft from the PTO tractor.
- clean the tiller (see chap.9 “Cleaning”)
- check that there are no oil leaks, repair any leaks present (ground pollution hazard)
- check and if necessary, replace any worn parts (see chap. 8 “Routine

maintenance”).



STOP FOR LONG PERIODS

When the machine is parked for long periods of time:

- activate the tractor parking brake
- lower the machine resting feet
- place the tiller on the ground
- turn the tractor engine off
- remove the ignition key from the control panel and keep it
- descend from the driver position
- detach the Cardan shaft
- rest the Cardan shaft on the relevant support
- pull out the split pin and the gudgeon and detach the tie rod (upper third point)
- fix the tie-rod to the appropriate support on the tractor
- pull out the slip pins and the connecting gudgeons and then the tractor's rear hydraulic lift arms from the tiller's hitch points
- get back onto the tractor
- start the tractor and move away carefully
- clean the tiller (see chap.9 “Cleaning”)
- lubricate all of the tiller with an anti-rust product.



Attention Hand cutting and shearing hazard

The machine must be parked on flat land and within a protected area, so as to prevent unauthorised staff from approaching.

EMERGENCY STOP

To stop the tiller in emergency conditions, just deactivate the rotation of the tractor PTO by activating the relevant control in the tractor control panel. At this point, engage the hand brake, switch the engine off, remove the key and keep it.

Identify the cause of the emergency stop and, if necessary, consult par. 12.2 “Troubleshooting” Table.

Decide:

- if necessary, take the equipment to the zero energy state
- if after-sales assistance must be requested
- if it can be repaired.

Once the cause of the emergency stop has been eliminated, the equipment has been re-started.

8. ROUTINE MAINTENANCE

ATTENTION

Only qualified operators and which have read and understood the safety prescriptions (Chap. 2) can carry out the operations described below. Moreover, they must check that there are no persons, animals and objects exposed in the dangerous area.

The operator must know and scrupulously follow the indications and must have put the machine out of service.

The periodic controls and the maintenance operations described in this chapter must be performed in the times and ways established and are the operator's responsibility.

Failure to comply with Standards and maintenance times jeopardises the good functioning of the machine and its duration and as a consequence the validity of the warranty.

For any other maintenance, consult par. 12.2 “Troubleshooting” Table or contact the Manufacturer or his after-sales centres.

Considering the complexity of the equipment, repairs, modifications, extraordinary maintenance different to those mentioned below **MUST NOT** be performed without having consulted the Manufacturer or its after-sales centres.



tres. Depending on the case, these will give authorisation to proceed along with all instructions necessary or they will recommend the intervention of one of its own technicians.

These precautions are due to the fact that, incorrect or unsuitable operations can lead to abnormal functioning conditions, causing damage to the equipment and risks to staff.



ATTENTION OVERTURNING, CRUSHING HAZARD

ATTENTION

Before performing maintenance, read all of this part in a way to be prepared for every inconvenience in time.

ATTENTION

Ensure stability of the equipment (tractor and tiller) before performing any maintenance intervention (the maximum gradient limit of the ground is 3°).

Before carrying out any maintenance operation, the operator must take the tiller to the zero energy state (See par. 2.10) 2.9)

The maintenance technician and any aids must have PPE available and wear them as required.



ATTENTION BURNS HAZARD

Do not perform repairs of which you have no knowledge. Always follow the instructions. If they are missing, contact the supplier or expert personnel.

Do not use lifting points different from those prescribed. Make sure that the chosen lifting device is suitable to carry out operations in compliance with safety Standards.

Do not leave the tractor engine running in closed places if they do not have a ventilation system suitable to remove toxic gas exhaust concentrated in the air.

Avoid prolonged and repeated skin contact with lubricants as they could harm skin and cause other syndromes.

Do not ingest fuels/lubricants/fluids. In the event of accidental contact the eyes, wash them well with water.

Do not weld in closed places or in those which are not appropriately ventilated.

Do not weld on painted surfaces, to prevent the formation of toxic vapours. Remove paint with suitable products and then wash the surfaces and let them dry.

SICMA INFORMS THAT ANY MODIFICATION OR TAMPERING OF THE TILLER OR ANY OPERATION PERFORMED IN DISAGREEMENT WITH THAT WRITTEN IN THIS MANUAL, ESPECIALLY FAILURE TO COMPLY WITH THE SAFETY PROVISIONS, AS WELL AS MAKING THE WARRANTY NULL AND VOID, RELIEVES SICMA FROM ANY LIABILITY FOR DAMAGE TO OBJECTS AND INJURY TO PERSONS.



**ATTENTION BURNS
HAZARD**

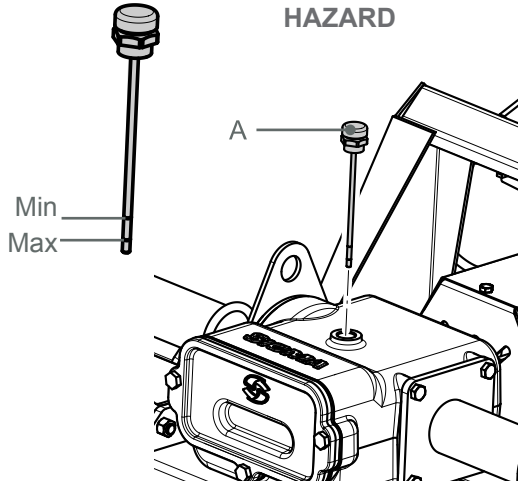

8.1 CONTROL AND REPLACEMENT OF THE OIL IN THE GEARBOX UNIT

ATTENTION

Wait for the gearbox to have cooled down before touching it.

ATTENTION

The operator must pay attention to oil leaks and perform relative repairs immediately. Moreover, liquids must not be poured onto the ground when topping-up or replacing the oil.

The oil level control in the gear unit box must be performed verifying the mark left by the oil itself on the load cap dip-stick A, which must be between the two reference signs (minimum and maximum).

The control must be performed every 50 working hours.

If top-up is necessary, proceed as follows:

- use a suitable wrench to loosen and extract the oil load cap A
- top-up the AGIP-ENI BLASIA 150 oil to the level on the dip-stick
- re-insert the load cap and tighten well

The oil on the gearbox unit must be replaced as follows:

- the first time after the first 50 hours of work
- every 500 hours of work.

To change the oil:

- position a container under the oil drain B
- loosen the oil drain cap B (lower part of the sump) and allow the oil to flow out completely
- dispose of the drained oil in appropriate containers for waste oils
- screw the previously unscrewed oil drain cap B
- loosen the oil load cap A (upper part of the sump)
- top-up using AGIP-ENI BLASIA 150 with the aid of a small funnel until the correct oil level is reached
- tighten the oil cap A when top-up has been completed

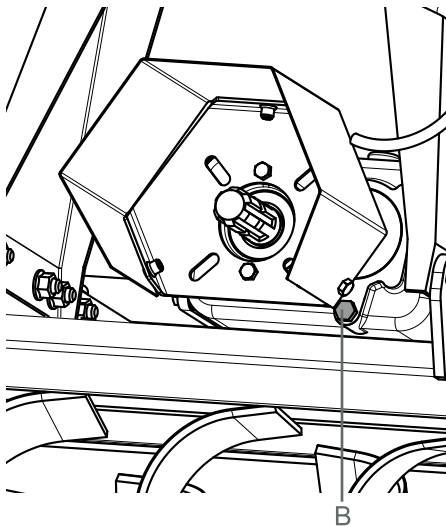

**ATTENTION POLLUTION
OF THE LAND AND WATER
TABLE HAZARD**



8.2 CONTROL AND REPLACEMENT OF THE OIL IN THE LATERAL DRIVE SUMP

The oil level in the lateral drive sump must be controlled every 50 working hours, verifying that it is visible inside the inspection window of the oil level lateral cap C.

If top-up is necessary, proceed as follows:

- use a suitable wrench to loosen and extract the oil load cap D
- top-up the AGIP-ENI BLASIA 150 oil until it is visible inside the cap C inspection window
- screw the load cap D again by tightening it using a 24 mm wrench.

The oil in the lateral drive sump must be replaced as follows every 500 hours of work.

To change the oil:

- position a container under the sump and allow the oil to flow out
- dispose of the drained oil in appropriate containers for waste oils
- loosen the oil load cap D
- top-up the AGIP-ENI BLASIA 150 oil until it is visible inside the cap C inspection window
- tighten the load cap D well

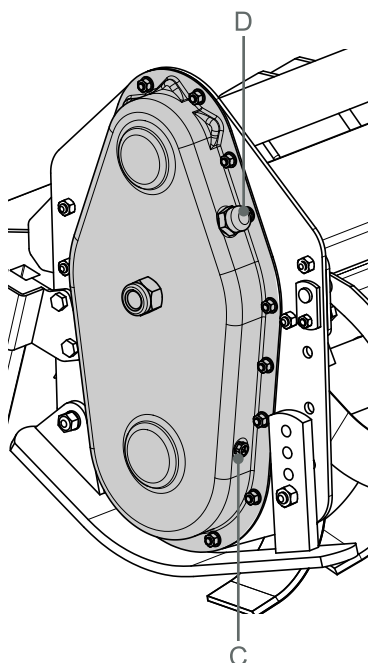

8.3 GREASING THE ROTOR SUPPORT

Greasing operations are performed using a relevant manual greasing pump, as shown in the figure.

The rotor external support must be greased every 50 working hours with AGIP GREASE MU EP 2 grease.

Inject grease by inserting the end of the greasing pump onto the greasing nipple E.

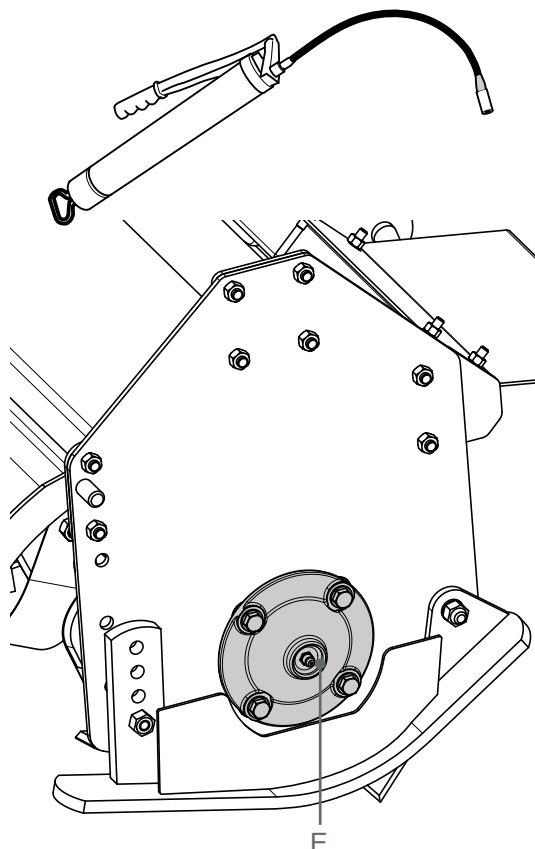

8.4 HOES REPLACEMENT

Every 50 hours of work, visually check the wear of the hoes. The hoes must be replaced when the ground has unworked rows due to lack of covering between the hoes and/or the hoes are visually worn.

Wear depends on the hours worked, the type of land etc....

Use of non-original tools can cause anomalous vibrations for the machine.

When replacing tools with the tiller lifted, do not trust the capacity of the tractor's hydraulic lift. Use mechanical posts or support tripods between the machine and the ground in order to avoid unwanted and dangerous descents of the machine.

To perform the following operations, the operator must wear gloves and glasses and must NEVER be positioned UNDER the rotor.

Operate as follows to replace the hoes:

- hitch the tiller to the tractor without Cardan shaft
- lift the tiller max. 10 cm from the ground
- strut the tiller with supports of suitable size
- loosen the bolts that fix the worn hoe using two suitable wrenches and, when the hoe has been removed, re-mount the new one immediately, positioning it exactly like the original
- tighten the bolts (see torque table par. 12.1)
- proceed in the same way for the other worn hoes.

8.5 CARDAN SHAFT

For lubrication and for maintenance interventions, behave as described in the use and maintenance manual by the manufacturer of the Cardan shaft installed.

9. CLEANING

ATTENTION GENERAL HAZARD

Only qualified operators and which have read and understood the safety prescriptions (Chap. 2) can carry out the operations described below. Moreover, these must check that there are no persons, animals and objects exposed in the dangerous area.

ATTENTION

During cleaning, use cut-proof gloves and accident-prevention shoes and pay particular attention not to put hands onto the hoes.

The operator must clean the tiller on solid, flat ground and must take the tiller to the zero energy state

If compressed air is used to clean the machine, appropriate glasses are needed.

It is good practice to wash the equipment externally with a jet of water after every job, especially the following parts:

- frame surface
- hoes
- mast
- cover
- rotor

Dry using compressed air after washing.



ATTENTION CRUSHING AND ENTRAPMENT HAZARD



ATTENTION CUTTING HAZARD

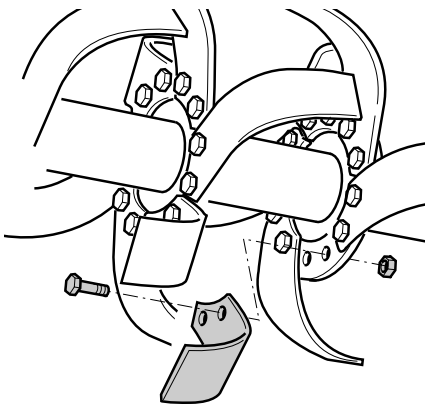

ATTENTION CUTTING HAZARD

To be able to clean the rotor compartment:

- lift the rear cover
- fix the chain in the relative hook
- if it is not possible to access the rear compartment, access the front compartment.

When washing has been completed, protect the metal parts that are not painted with lubricant oil.

10. STORAGE AND WINTERING

If the machine is immobilised for long periods, it must be stored in a place sheltered from atmospheric conditions and be protected to avoid damage. Before setting it aside, clean the whole machine and lubricate all mechanical parts to protect them from rust.

Before setting the machine aside for long periods, operate as follows:

- free the rotor and the tools from tilling residues
- clean the machine thoroughly
- Carry out a general visual control of the machine to identify structural damage, to detect deep paint abrasions, to check that all original safety pictograms are in place, and that they are integral and legible
- grease all mechanical parts and fastening pins
- if possible, recover the machine in a covered place, on flat and consistent ground.



If the machine has a safety device (clutch disks), after having made note of the height of the compressed springs, it is recommended to loosen the screws (see par. 6.2) that compress the springs in order to prevent the disks blocking against each other (seizure).

11. SCRAPPING

In the event of scrapping, the machine must be disposed of in suitable waste disposal sites, in compliance with the Law in force.

In Italy, before scrapping, separate the plastic or rubber parts from the metal ones. The parts made only in plastic, aluminium, steel, can be re-cycled, if collected by appropriate centres.

Recover any waste oils and dispose of them at relevant collection centres. Exhaust oil must be appropriately recovered and not littered in the environment because, according to the applicable provisions of law, it is classified as toxic waste and must as such be assigned to specific collection centres. For the collection of waste oils, it is mandatory to connect the "Consorzio Obbligatorio Oli Usati" (Mandatory Consortium for Used Oils) (www.cooi.it; free phone 800-863048).

For the other countries, refer to the relative anti-pollution regulations in force.



**ATTENTION POLLUTION
OF THE LAND AND WATER
TABLE HAZARD**

12. QUICK CONSULTATION TABLES

The following pages, state the conditions and hypothesis of intervention for each of the cases stated above, in table form.

12.1 COUPLING TORQUE TABLE

Check the efficiency of all screws and bolts every day. If necessary, replace them immediately and repositioning them (screws, washers, nuts) in the same sequence as they were removed.

COUPLING TORQUE				
bolt class				
Threading	8.8		10.9	
	Nm	Lb-ft	Nm	Lb-ft
M6	11	8.5	17	12
M8	28	20	40	30
M10	55	40	80	60
M12	95	70	140	105
M14	150	110	225	165
M16	240	175	305	225
M18	330	250	475	350



12.2 TROUBLESHOOTING TABLE



NOTE

Before actuating the solutions suggested, make another attempt at functioning to check if the anomaly persists. In the event of intervention, start at the most elementary solution. If the anomaly remains in spite of the solutions, contact the manufacturer's after-sales centres.

ANOMALY	CAUSE	REMEDY
Oil leak from the gear box or lateral drive sump	<ul style="list-style-type: none"> • Too much oil in the box or lateral sump • Vent cap with faulty valve • Load/drain/level caps loose • Damaged gaskets 	<ul style="list-style-type: none"> • Restore the correct oil level • Replace the vent cap • Tighten the load/drain/level caps • Replace the gaskets
Tilling not uniform	<ul style="list-style-type: none"> • Worn or damaged tools • Machine not well adjusted (unaligned skids or rollers) • Machine clogged 	<ul style="list-style-type: none"> • Replace the tools • Carry out adjustments • Decrease tractor advancement speed • Clean the tilling chamber
Bevel gear unit overheating	<ul style="list-style-type: none"> • Insufficient oil • No oil • Heavy ground 	<ul style="list-style-type: none"> • Restore the oil level • Reduce advancement speed
Premature tool wear	<ul style="list-style-type: none"> • Sandy or muddy ground 	<ul style="list-style-type: none"> • Reduce advancement speed
Tools breakage	<ul style="list-style-type: none"> • Stony ground 	<ul style="list-style-type: none"> • Reduce advancement speed
Excessive power absorption	<ul style="list-style-type: none"> • Volume of land worked too high • Excessive work depth • Excessive rotor rotation speed • Tilling chamber clogging (humid land) 	<ul style="list-style-type: none"> • Decrease working depth by regulating skid heights • Reduce gear speed • Lift the rear cover to facilitate the escape of earth
Machine noise or vibrations	<ul style="list-style-type: none"> • Very hard ground • Rotor unbalanced or damaged • Damaged, worn or missing tools • Worn bearings • PTO not correctly positioned with respect to the tractor PTO • The tiller works too tilted forward or in reverse 	<ul style="list-style-type: none"> • Reduce advancement speed • Check/replace the rotor • Check/replace the tools • Replace bearings • Adjust the Cardan shaft correctly • Adjust the upper third point so that the tiller surface is parallel to the ground.
Little pulverization of the land	<ul style="list-style-type: none"> • Rear cover too open • Excessive advancement speed • Rotor rotation speed too slow 	<ul style="list-style-type: none"> • Lower rear cover • Reduce advancement speed • Increase gear speed
The tiller bounces of the land	<ul style="list-style-type: none"> • Hoes positioning not helical • Hoes inverted, worn or broken • Rotor deformed or with foreign bodies between the hoes • Ground too hard 	<ul style="list-style-type: none"> • Restore the correct helical positioning of the hoes • Replace the hoes • Replace the rotor • Pass several times

12.3 MAINTENANCE TABLE

	INTERVAL IN HOURS	DESCRIPTION OF THE INTERVENTION
A	AFTER THE FIRST 50 HOURS OF WORK	<ul style="list-style-type: none"> replace the oil in the gear unit box
B	EVERY 50 HOURS OF WORK	<ul style="list-style-type: none"> check the oil level in the gear box unit and top-up to the correct level if necessary check the oil level in the lateral drive sump and top-up if necessary grease the external rotor lateral support
C	EVERY 500 HOURS OF WORK	<ul style="list-style-type: none"> replace the oil in the gear unit box replace the oil in the lateral drive sump

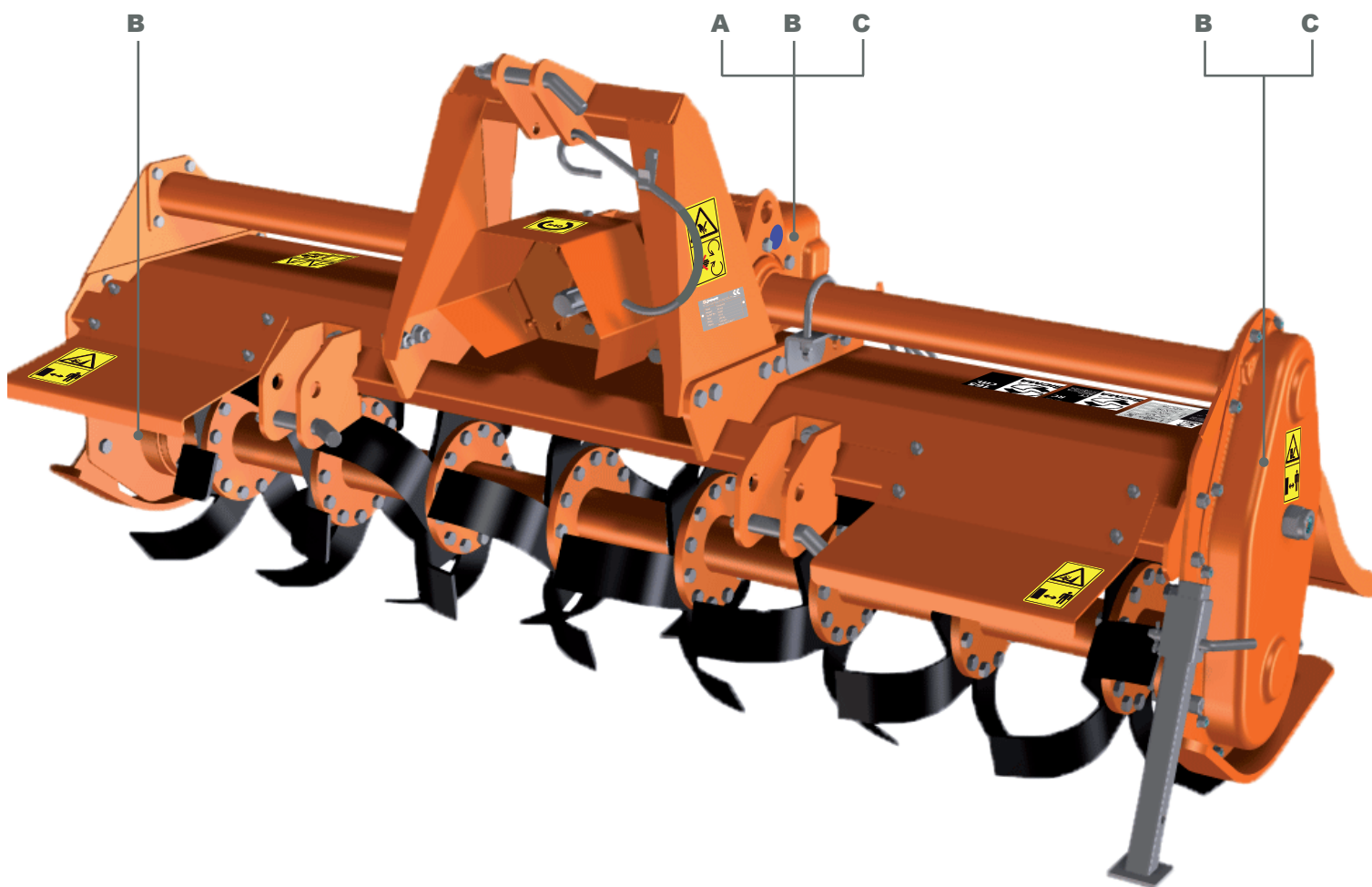

RECOMMENDED LUBRICANTS	
OIL	AGIP-ENI BLASIA 150
GREASE	AGIP GREASE MU EP 2



Maintenance must be carried out only after having read and understood the entire tiller manual.

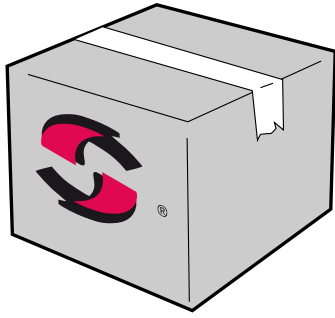

13. SPARE PARTS

Repairs and replacements must be performed using original spare parts, which must be requested from the Dealer. Remember that the request for spare parts must be correct and accompanied by the following indications:

- machine type
- serial number
- code and description of the spare part requested can be obtained from the Spare Parts Exploded Diagram;
- quantity requested.

Given the particular stress to which the equipment is subjected and for safety reasons, if pieces are replaced, only use original spare parts.

14. WARRANTY

In order to make use of the contractual warranty supplied by the Manufacturer, the operator must scrupulously comply with the precautions indicated in the Use and Maintenance Manual and in particular:

- respect the limits of use envisioned by the Manufacturer;
- do not make modifications or variations to the machine without the written approval of the Manufacturer;
- always perform all maintenance interventions prescribed;
- always use original spare parts;
- make sure that the staff assigned to using the vehicle has the necessary skill requisites and training.

The contractual warranty is not applied if the conditions stated above are not respected, even also partially.

The use of spare parts not approved by the Manufacturer invalidates any warranty and relieves the Manufacturer or Dealer from any liability due to malfunctioning or accidents.

The removal or the modification of guards and protections relieves the Manufacturer from all liability due to damage/injury caused to objects and/or persons.







SICMA S.p.A.
Contrada Cerreto, 39
66010 MIGLIANICO (CH) - ITALIA
Tel. +39 087195841 - fax +39 0871950295