

CE

EN

English

TILLER ZLL /090•110•120•130•140•150 USER AND MAINTENANCE MANUAL



Light fixed tiller

TRANSLATED INSTRUCTIONS

903874011~01

12/2020



MADE IN ITALY

CONTENTS

1.	INTRODUCTION	5
1.1	SOME NOTES REGARDING THE USER MANUAL	5
1.2	DECLARATION OF CONFORMITY	6
1.3	DELIVERY LETTER	7
1.4	TILLER IDENTIFICATION AND MANUAL CODE	7
1.5	GENERAL DELIVERY NOTES	8
1.6	TILLER COMPOSITION	9
2.	SAFETY	10
2.1	LIST OF RESIDUAL RISKS	10
2.2	SAFETY PRESCRIPTIONS	10
2.3	DEFINITIONS	10
2.4	CONVENTIONAL SYMBOLS	11
2.5	OPERATOR REQUIREMENTS	11
2.6	CLOTHING AND PPE	12
2.7	SAFE USE OF THE MACHINE	12
2.8	INTENDED USE	12
2.9	SAFETY DEVICES	13
2.10	POSITION AND MEANING OF THE PICTOGRAMS	13
3.	UNLOADING AND UNPACKING THE TILLER	16
3.1	TILLER PROTECTED BY HEAT-SHRINKABLE FILM	16
3.2	TILLER PACKAGED IN WOODEN BOX	17
4.	TECHNICAL SPECIFICATIONS	18
5.	START-UP	19
5.1	CONNECTING THE TILLER TO THE TRACTOR	19
5.2	PTO DRIVE SHAFT COUPLING	20
5.3	CHECK THE STABILITY OF THE TRACTOR-TILLER COMPLEX.	21
5.4	ROAD TRANSPORT	21
6.	ADJUSTMENTS	22
6.1	CLUTCH ADJUSTMENT	22
6.2	WORK HEIGHT ADJUSTMENT	22
7.	USE	23
8.	STOPS	24
9.	CLEANING	25
10.	ROUTINE MAINTENANCE	25
10.1	CHECK AND REPLACEMENT OF OIL IN THE TRANSMISSION ASSEMBLY	26
10.2	CONTROL AND REPLACEMENT OF THE OIL IN THE LATERAL DRIVE SUMP	27
10.3	GREASING	28
10.4	HOE REPLACEMENT	28
11.	PTO DRIVE SHAFT	29
12.	STORAGE AND WINTERING	29
13.	SCRAPPING	29
14.	QUICK CONSULTATION TABLES	30



14.1	TABLE OF TIGHTENING TORQUES	30
14.2	TROUBLESHOOTING	30
14.3	LUBRICATION INTERVALS	31
15.	SPARE PARTS	32
16.	WARRANTY	32
17.	NOTES	33



Congratulations on your purchase of the

ZLL Tiller

The ZLL Tiller is manufactured by SICMA S.p.A, which has been manufacturing agricultural machines for over 40 years.

The ZLL Tiller has all safety and quality requisites required for this type of equipment.

Remember that to obtain the best performance and to optimise the productivity features, you must be thoroughly familiar with, and observe all, the instructions and information contained in this manual.

1. INTRODUCTION

1.1 SOME NOTES REGARDING THE USER MANUAL

It is important to know that the USER MANUAL is not an accessory of the Tiller, but an INTEGRAL PART and a SAFETY MEASURE (EN 12100-1).

For this reason:

- Keep it in good condition;
- Store it inside the document holder canister affixed to the Tiller;
- Hand it over to any operator, maintenance technician, handler or subsequent owner.

In this way, the Tiller can be used at its full potential in utmost safety.

The manual must remain intact, complete with all its pages and must be kept away from moisture and heat; during its consultation, prevent it from becoming wet or dirty to guarantee optimum legibility.

In case of loss or deterioration of this manual, request a copy from the Manufacturer or from the nearest Dealer including the identification code on the cover.

To ease consultation, the manual has been divided into parts, so that every phase can be easily understood.

With these precautions, SICMA intends to unequivocally draw the operator's attention to any hazardous situations that may arise.

We also remind you that the information, descriptions and illustrations contained in this manual reflect the state of the art at the time of marketing the machine.

The Manufacturer reserves the right to make, at any time, any changes to the machines for technical or commercial reasons. These changes do not require the Manufacturer to act on vehicles sold so far, nor to consider the present publication inadequate.

Any additions that the Manufacturer deems appropriate to provide later, will need to be kept with the manual and considered to be part of it.



WARNING!

The drawings and any other documents delivered together with the tiller are the property of SICMA which reserves all rights thereof and, therefore, cannot be disclosed to third parties without its written consent. Therefore, any reproduction, even partial, of the text and illustrations is strictly prohibited.



1.2 DECLARATION OF CONFORMITY

The machine is delivered accompanied by the following Declaration of Conformity.

EC DECLARATION OF CONFORMITY

The company

Sicma s.p.a. - C.da Cerreto, 39 - 66010 Miglianico (Ch) - Italy
Tel.: +39 0871 95841 - Fax: +39 0871 950295
e-mail: info@sicma.it - http://www.sicma.it

hereby declares that:

product: TILLER
model: ZLL
serial number:

complies with the essential requirements for safety and health of Directive 2006/42/CE.

To fulfil the above mentioned Directive have been applied the following harmonised standards:

-UNI EN ISO 4254-1:2010, EN ISO 4254-5:2009, UNI EN ISO 12100-1:2009, UNI EN ISO 12100-2:2009

and the technical standards and specifications

- ISO 11684:1995, ISO 13852:1996, UNI 9456:1989.

The person authorised to compile the technical file is Mr. Lorenzo Aurora



Miglianico, 15/03/2020

Chiara Aurora
AMMINISTRATORE UNICO



1.3 DELIVERY LETTER

The Tiller was designed in compliance with the Directive 2006/42/EC and was designed observing the guidelines of the technical standards regarding Tillers, specifically UNI EN ISO 4254-1:2010 and UNI EN ISO 4254-5:2009.

Therefore, the machine does not represent a danger for the operator if used according to the instructions in this manual and on condition that the safety devices are kept constantly efficient.



WARNING!

SICMA POINTS OUT THAT ANY CHANGES TO OR TAMPERING WITH THE TILLER OR ANY OPERATION PERFORMED THAT IS NOT IN ACCORDANCE WITH WHAT IS PRESCRIBED IN THIS MANUAL, IN PARTICULAR FAILURE TO COMPLY WITH THE SAFETY REQUIREMENTS, AS WELL AS INVALIDATING THE WARRANTY, EXEMPTS SICMA FROM ANY LIABILITY FOR DAMAGES TO PROPERTY AND PERSONS.

Some of the devices described in this manual may not be present on your machine, as they vary depending on the chosen set up and the market of destination.

1.4 TILLER IDENTIFICATION AND MANUAL CODE

For any request for assistance or information regarding the Tiller, contact SICMA or its assistance centres, always mentioning the model and serial number, both reported on the plate.

Properly transcribe the identification code of this manual which is shown on the cover, so that, in the event of loss or damage to this manual, it is possible to request a copy from SICMA or from the nearest Dealer. If necessary, also mention the serial number of the equipment visible in the CE marking.



SICMA
SICMA SPA - C.da Cerreto, 39 - 66100 Miglianico (Ch) - Italy
Tel.: +39 0871 95841 Fax: +39 0871 950295 - info@sicma.it - www.sicma.it

Type:	TILLER		
Model:	ZLL 140		
Year:	2020		
Mass (Kg):	176	Input (rpm):	540
Serial No #4134216002#			
MADE IN ITALY			

1



1.5 GENERAL DELIVERY NOTES

The Tiller, its parts and accessories are normally delivered by lorry or container. Upon receipt of the machine, check that the details of delivery correspond to the order specifications (see packing slip or packing list) and that there is no damage to the Tiller or to its accessories.

Spare parts or ancillary equipment are sometimes placed in separate containers.

In the event of damage or missing parts immediately inform SICMA or its local representatives, the carrier or its insurance agent, providing details and/or photos.

The Tiller is delivered by SICMA equipped with the following:

- 1- PTO DRIVE SHAFT;
- 2- TILLER USE AND MAINTENANCE MANUAL;
- 3- PTO DRIVE SHAFT USE AND MAINTENANCE MANUAL;
- 4- CE DECLARATION OF CONFORMITY.

2

TILLER ZLL /090-110-120-130-140-150 USER AND MAINTENANCE MANUAL



Light fixed tiller

TRANSLATED INSTRUCTIONS
932374011-01 1/2020



3

PM14 • PM57 • PM80E



ENG • Users manual

D • Bedienungsanleitung

F • Manuel d'utilisation

I • Manuale d'istruzioni

ES • Manual de instrucciones

P • Manual de instruções

GR • Руководство по эксплуатации

SL • Navodila za uporabo



Cod:1140917_D

4

EC DECLARATION OF CONFORMITY

The company

Sicma s.p.a. - C.da Cerreto, 39 - 66010 Miglianico (Ch) - Italy
Tel.: +39 0871 95841 - Fax: +39 0871 950295
e-mail: info@sicma.it - http://www.sicma.it

hereby declares that:

product: TILLER
model: ZLL
serial number:

complies with the essential requirements for safety and health of Directive 2006/42/CE.

To fulfil the above mentioned Directive have been applied the following harmonised standards:
-UNI EN ISO 4254-1:2010, EN ISO 4254-5:2009, UNI EN ISO 12100-1:2009, UNI EN ISO 12100-2:2009

and the technical standards and specifications
- ISO 11684:1995, ISO 13852:1996, UNI 9456:1989.

The person authorised to compile the technical file is Mr. Lorenzo Aurora



Miglianico, 15/03/2020
Chiara Aurora
AMMINISTRATORE UNICO
Chiara Aurora



1.6 TILLER COMPOSITION

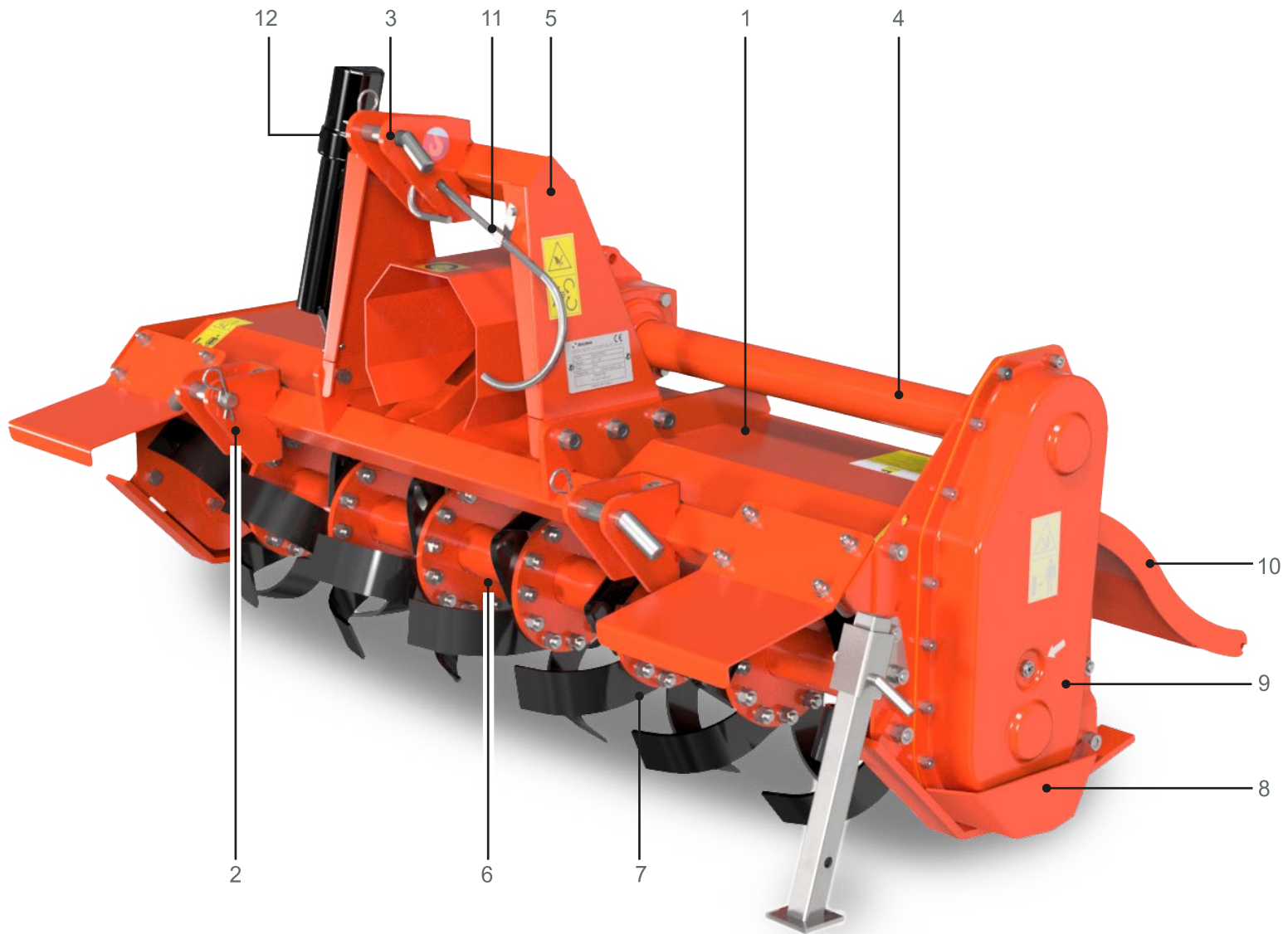

Ref.	Description
1	Frame
2	Lower 3-point hitch
3	Upper 3-point hitch
4	Drive shaft extension pipe
5	3-point hitch mast
6	Rotor
7	Hoes
8	Side skids
9	Drive sump
10	Bonnet
11	Drive shaft hook
12	Document canister



2. SAFETY

2.1 LIST OF RESIDUAL RISKS

Even though SICMA has done everything possible to ensure that the equipment meets the current safety standards as laid down in 2006/42/CE Directive, some residual risks, although reduced, still persist:

- CUTTING HAZARD DUE TO CONTACT WITH TOOLS (rotor);
- ENTANGLEMENT/Dragging HAZARD (rotor and PTO drive shaft);
- LIMB SHEARING HAZARD (rear covers);
- OVERTURNING/CRUSHING HAZARD (Tiller handling);
- BURN HAZARD (bevel gearbox);

Therefore, whoever uses the machine or maintains it, must be a trained person aware that, despite using all the protections provided for by current regulations, there is still the possibility of the persistence of risks for the physical safety of operators and for the integrity of the equipment itself.

WARNING!

Tiller operators must read and understand the use and maintenance manual and ALWAYS ensure it is readily available in order to be able to consult it for any requirement.

The use and maintenance manual specifies all the information required by point 1.7.4 (user instructions) of Annex 1 of the Machinery Directive, and a specific request is made to observe the requirements to avoid the occurrence of accidents that can cause damage to property or injury to persons.

2.2 SAFETY PRESCRIPTIONS

Any operator, before using the equipment, categorically **MUST** have read and understood the safety instructions and the entire manual.

- The machine is not suitable for use in sectors other than in agriculture: use other than the one specified is considered improper.
- The manual must always be readily available so that it can be consulted if necessary. If it is lost or damaged, it will be necessary to request a replacement copy from SICMA.
- Under no circumstances climb, sit or lean on the equipment, neither during operation nor in the Zero Energy State.
- The operator must ensure that during operation of the machine no person is standing within its range of action. Never operate the machine near people standing or passing within the operating range of the machine.

2.3 DEFINITIONS

In this use and maintenance manual and on the equipment itself, it is possible to find several symbols whose meanings are illustrated below.

HAZARD:

A potential source of physical injury or damage to health.

HAZARDOUS AREA:

Any area within and/or in proximity of a machine in which the presence of a person constitutes a risk for the safety and health of the same.

The hazardous area is the area around the machine (connected to the tractor) up to a distance of one metre.

EXPOSED PERSON:

Any person that is found wholly or partly in a dangerous area.

CRITICAL AREA:

The critical area is that between the tractor and the equipment (PTO drive shaft area).

ZERO ENERGY STATE:

The "Zero Energy State" is defined as the state in which the Tiller is to be set before performing any cleaning, lubrication and maintenance operation. The operator must carry out the following to set the Tiller to the "Zero Energy State":

- Place the Tiller on flat, non-yielding ground;
- Disable the power take-off;
- Apply the tractor parking brake;
- Switch off the tractor, remove the key and store it;
- Disconnect the PTO drive shaft from the tractor's PTO;
- Put the outrigger in the stop position;
- Disconnect the 3-point hitch.

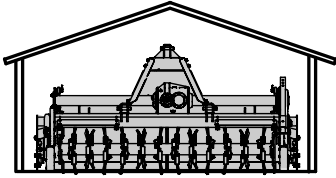

2.4 CONVENTIONAL SYMBOLS

In consulting this operation and maintenance manual and on the Equipment itself a number of symbols are used whose meaning is illustrated below and on the following pages.



RECOMMENDATION:

It refers to a working method implemented in the field, knowing well that each operator will then develop their own way of working.



NOTE:

Draws the attention of staff to information considered to be of high importance.



WARNING:

Draws the attention of staff to information, which, if not respected, may cause slight injury to persons or damage to the machine.



CAUTION HAZARD:

Informs the staff assigned that the operation described has the risk of physical injury if not performed with respect to the Safety Standards.



MACHINE OPERATOR OR DRIVER:

Identifies the qualified staff, i.e. with specific skills, as the operations are completely manual. Therefore, the preparation and sensitivity of the machine operator are referred to in order to obtain the best qualitative results. The operator is therefore strictly forbidden from performing tasks that should be performed by the maintenance technician.



MECHANICAL MAINTENANCE TECHNICIAN:

Qualified technician who works on mechanical components to carry out all the necessary adjustments, maintenance operations and repairs.



NON-ROUTINE INTERVENTIONS:

Any maintenance interventions highlighted by the symbol on the side must be requested to the Manufacturer or directly to authorized service centres.



PERSONAL PROTECTION EQUIPMENT (P.P.E.):

If any of these symbols are present on the side panel, suitable personal protection equipment must be worn by the operator as the risk of accident is implicit.

2.5 OPERATOR REQUIREMENTS

- The machine must be used by only one operator driving the tractor.
- The machine must only be used by authorised personnel, educated and properly trained. The operator, in addition to having read and understood the instructions contained in this manual, must have gained a sufficient preparation on the proper use of the machine and must be in possession of a driving license. We remind the operator to contact the retailer or the

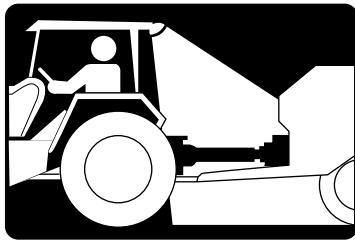

manufacturer if they are unsure about the use of the machine and the interpretation of this manual.

- Do not use the equipment if you are tired, ill or under the effects of alcohol, medicines or drugs.
- When driving the tractor, the operator must manage Tiller operation using the controls available on the control console of the tractor.

2.6 CLOTHING AND PPE

Personnel must use the safeties provided and PPE during use and maintenance of the vehicle.

The correct clothing to be worn during maintenance operations and use of the Tiller is:

- Gloves;
- Accident-prevention shoes or boots with iron toe-cap;
- Protective goggles;
- Overalls with elasticated wrists, ankles and waist.

Furthermore:

- Given that the machine can generate emissions of dust during operation, if the tractor does not have a closed cab, the operator must wear an anti-dust mask (especially in dry and dusty areas);
- In the event that the tractor is not equipped with a soundproof cab, the operator must wear protective headphones (especially on stony ground);
- The operator assigned to operate the machine is advised to avoid wearing items of clothing that can cause entanglement (scarves, belts, wide sleeves, etc.).

2.7 SAFE USE OF THE MACHINE

- The machine is usually used during the day. If night use is exceptionally required or in conditions of reduced visibility, the tractor's lighting system or any auxiliary lighting system must be used.
- Check the equipment carefully before each start-up.
- Check the tightness of the nuts and bolts daily (see tightening table sec. 14.1) and check that the metal structures are in good condition: repair if necessary.
- Make sure that the snap hooks of the PTO drive shaft guard retaining chains are engaged to the appropriate slots so that the plastic guard remains fixed and does not rotate with the shaft itself.
- Before leaving the tractor, and before any maintenance operations, engage the parking brake, stop the engine, remove the ignition key from the dashboard and keep it safe.
- When the machine is in operation, the blades are rotating rapidly: remain at a safe distance to prevent accidental contact with moving tools or from being struck by any objects projected by these.

WARNING!

It is absolutely forbidden to tamper with the equipment for any reason. Any arbitrary modification made to this machine exempts SICMA from any responsibility for damages or injuries caused to operators, third parties and property and will result in invalidation of the warranty.

2.8 INTENDED USE

The ZLL Tiller has been designed expressly to work land and has been developed with the sole purpose of loosening, turning and oxygenating the land in order to prepare it for sowing.

It has been constructed to be combined with tractors of adequate size, capable of withstanding their weight, equipped with a hydraulic lift, with universal three-point coupling and rear power take-off for the operation of the tiller via a PTO drive shaft coupling.

INJURY HAZARD!

Given the particular stress to which the equipment is subjected, if it is necessary to replace certain parts of the components, request only original spare parts.

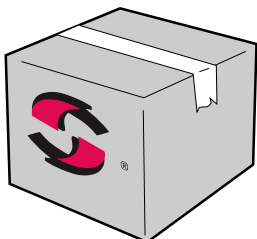



WARNING!

The use of non-original spare parts exempts SICMA from any responsibility for damage or injuries caused to operators, third parties and property and causes immediate forfeiture of the warranty.

USE ENVIRONMENT

The Tiller works:

- In open fields, on land that is non friable, not excessively stony and with a maximum slope of 3°;
- In environments with a temperature from 0° ÷ 50°C.

IMPROPER USE

Any use different to that declared is to be considered improper.

REASONABLY PREDICTABLE INCORRECT USE

The operator may sometimes use the Tiller incorrectly: below are some examples of what should be avoided.

The operator must not:

- Couple the Tiller to vehicles of unsuitable power or weight.
- Connect the Tiller to a PTO drive shaft with unsuitable power.
- Work in reverse.
- Use the Tiller without securing the shock absorbing tie-rods of the three-point hitch of the tractor's lifter.
- Lift the Equipment when the power take-off is rotating.
- Traverse bends or reversals with the Tiller beneath the ground.
- Perform makeshift repairs in order to complete the work.
- Use the Tiller to carry and/or lift persons, animals or objects.
- Work on land with slopes greater than 3°.

2.9 SAFETY DEVICES

Before using the machine, make sure that all safety devices are properly in place and in good condition. If there are failures or damage to the guards, replace them immediately.

Do not tamper with or bypass the safety devices for any reason. After every cleaning and maintenance intervention, all of the safety devices must be restored and/or all protection housings closed. Also verify that there are no tools, rags or other materials inside the transmission compartments.

2.10 POSITION AND MEANING OF THE PICTOGRAMS









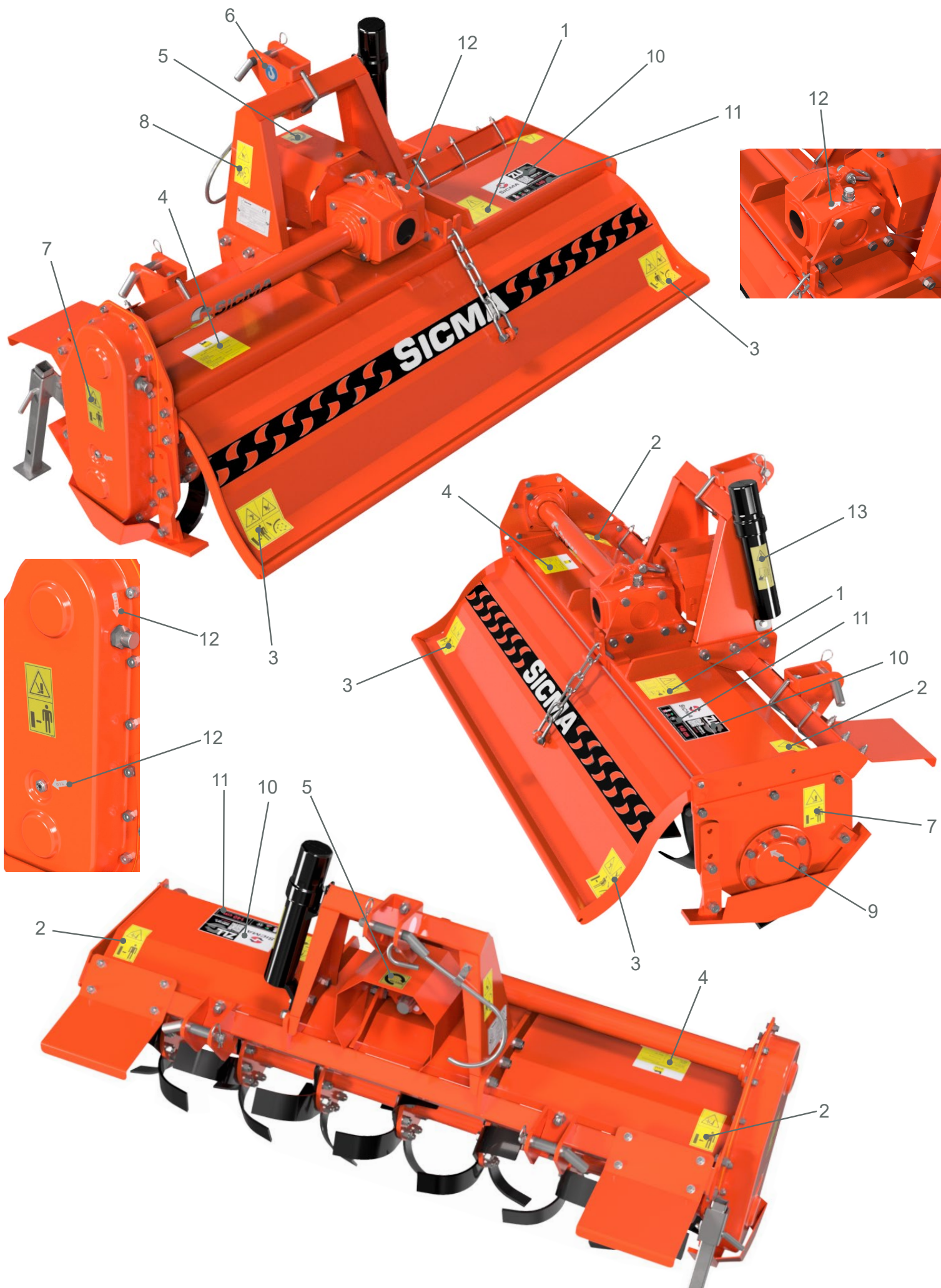

The signs affixed to the machine provide a series of important indications: their observance safeguards the physical safety of the operators and guarantees the optimal effectiveness of the equipment.



Ensure therefore that the safety pictograms are in good condition and, if they are damaged, replace them with other original ones by relocating them in their place of origin.

Then request the new pictograms from SICMA or from the nearest Dealers, citing the reference codes indicated in the following pages.

LOCATION OF SAFETY PICTOGRAMS



REF.	STICKER	DESCRIPTION	CODE																
1		CAUTION Read all instructions and safety rules carefully before using the machine. Switch off the engine and remove the key before carrying out maintenance or repairs.	4781029 Qt. 1																
2		ROTATING PARTS Danger of injury to the feet, keep a safe distance from the machine when it is working.	4781011 Qt. 2																
3		EJECTED OBJECTS Keep a safe distance from the machine. Risk of injury to the hands: do not open or remove the safety guards while the machine is in motion.	4781019 Qt. 2																
4	 <table border="1" data-bbox="700 801 991 976"> <thead> <tr> <th colspan="2">usare esclusivamente use only</th> <th colspan="2">user exclusivement</th> </tr> </thead> <tbody> <tr> <td>olio idraulico hydraulic oil huile hydraulique</td> <td></td> <td>OSO 46-68</td> <td></td> </tr> <tr> <td>riduttore gear oil huile pour engranages</td> <td></td> <td>Blasia 150</td> <td></td> </tr> <tr> <td>lubrificazione a grasso grease lubrication graissage</td> <td></td> <td>Grease MU EP 2</td> <td></td> </tr> </tbody> </table>	usare esclusivamente use only		user exclusivement		olio idraulico hydraulic oil huile hydraulique		OSO 46-68		riduttore gear oil huile pour engranages		Blasia 150		lubrificazione a grasso grease lubrication graissage		Grease MU EP 2		USE ENI LUBRICANTS ONLY For the hydraulic system: OSO 15-32-46-68 oil; For the gear reducer: Blasia 150 oil; For greasing: GREASE MU EP 2.	4781099 Qt. 1
usare esclusivamente use only		user exclusivement																	
olio idraulico hydraulic oil huile hydraulique		OSO 46-68																	
riduttore gear oil huile pour engranages		Blasia 150																	
lubrificazione a grasso grease lubrication graissage		Grease MU EP 2																	
5		PTO rpm Use of a 540 rpm power take-off.	4781010 Qt. 1																
6		HOOKING POINT Fixing point for lifting the machine.	4781031 Qt. 1																
7		LIMB INJURY HAZARD Keep a safe distance from the machine when it is working.	4781012 Qt. 2																
8		INJURY HAZARD TO HANDS Rotating parts: maintain a safe distance from the machine.	4781013 Qt. 1																
9		GREASE Indication for injection of lubricating grease.	4781009 Qt. 1																
10		MACHINE INFO ZLL	4781201 Qt. 1																

11		WIDTH INFO	000-090; 000-100; 000-120; 000-130; 000-140; 000-150 Qt. 1
12		OIL Oil filling point	4781008 Qt. 3
13		DOCUMENT-HOLDER CANISTER Keep the manual inside this canister	- Qt. 1

3. UNLOADING AND UNPACKING THE TILLER



CRUSHING HAZARD!

Qualified staff that have read and understood the safety prescriptions must unload the Tiller from the lorry and handle the Equipment in the work place. These manoeuvres should be supervised by an experienced manager. In all cases, make sure that there are no people, animals or objects in the unloading area.

The Tiller is normally transported on a lorry, sometimes without packaging, sometimes protected by heat shrinkable film and other times in wooden crates.



NOTE!

Before unloading the equipment from the truck, read this entire sequence in order to be prepared for all events.



OVERTURNING AND CRUSHING HAZARD!

Tiller unloading must be carried out slowly and with the utmost care in an area completely free from persons or objects.



RISK OF THE TILLER FALLING FROM THE TRUCK!

Recall that no matter how stable the equipment, during subsequent transportation procedures, it must ALWAYS:

- Be well secured to the lorry, paying attention not to crush any hydraulic pipes;
- Be placed in the middle of the lorry and not near the edges, in order to avoid losing the Tiller on the road in case it overturns due to turns or broken road, with very serious consequences.

3.1 TILLER PROTECTED BY HEAT-SHRINKABLE FILM

Release the Tiller from any fixing devices used to fasten it to the means of transport.

Before lifting using the lorry's lifting arm, check that all locking mechanisms (snap hooks, shackles, etc.) and the ropes/chains used are in good condition; each must be able to lift the weight of the machine (see weight in sec. 4 "Technical specifications").

After harnessing the Tiller, lift it a few centimetres to check the correct distribution of weights: in case of imbalance, reposition the Tiller on the platform, correctly adjust the harness and the length of the ropes/chains and repeat the procedure.

Lift the Tiller from the deck of the means of transport to a height of approximately 30 cm, unless obstacles are present, so that it does not swing. Position the Tiller on the ground in proximity of the tractor.

Remove the ropes and the chains from the Tiller.

Once on the ground, unpack the equipment as described below.

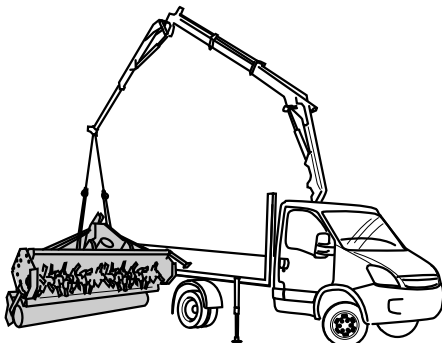

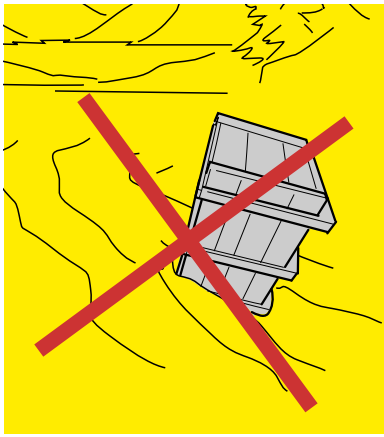

CUTTING HAZARD!

In the event that the Tiller arrives wrapped in a protective film, remove it with the aid of a cutter wearing anti-cut gloves; take care not to injure yourself and not damage the Tiller itself.



CONTAMINATION HAZARD!

Do not dispose of the packaging in the environment, but contact specialist collection agencies. Check the transport document or packing list supplied and, if necessary, act as described in section 1.5 "General notes on delivery".

3.2 TILLER PACKAGED IN WOODEN BOX

If the Tiller is contained inside a wooden box, use a forklift of adequate capacity for unloading (to ascertain the weight of the Tiller, refer to the technical specifications table in sec. 4).

Release the Tiller from any fixing devices used to fasten it to the means of transport.

Insert the forklift forks into the appropriate slots on the platform.

Lift the box from the walking surface of the means of transport by a maximum height of 30 cm, unless hindered by obstacles.

Place the crate on the ground in the vicinity of the tractor.

With a suitable tool and wearing protective gloves, remove the wooden crate.

Harness the Tiller with ropes and/or chains of adequate capacity, lift the equipment by a few centimetres and remove the lower part of the wooden crate. Place the Tiller on the ground and approach the tractor in reverse so that the tractor PTO is positioned frontally to the one of the Tiller.

Couple the Tiller to the tractor using the 3-point hitch according to section 5.1.

Check the transport document or packing list supplied and, if necessary, act as described in section 1.5 "General notes on delivery".

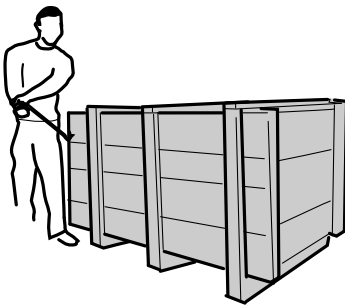

4. TECHNICAL SPECIFICATIONS

The table below outlines the technical specifications of the ZLL Tiller.

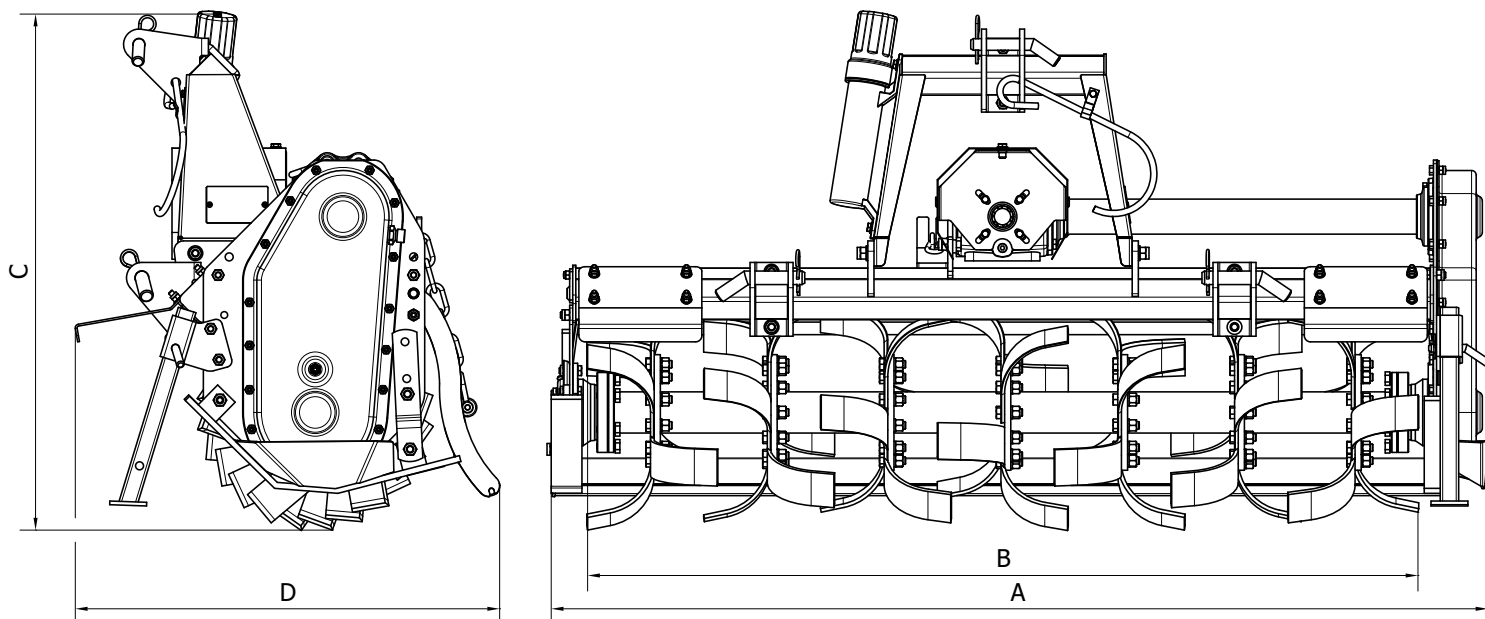

			Machine type						
			ZLL/090	ZLL/100	ZLL/110	ZLL/120	ZLL/130	ZLL/140	ZLL/150
Tiller	Overall width (A)	mm	1025	1125	1225	1325	1425	1525	1625
	Working width (B)	mm	900	1000	1100	1200	1300	1400	1500
	Height (C)	mm	840						
	Side clearance (D)	mm	690						
	Work depth	mm	160						
	Weight (standard)	kg	126	136	146	160	166	176	180
		lbs	276	300	322	353	366	388	397
Side transmission	-	Gears or chain							
Rotor	Number of rotor revolutions	Revs/min	240						
	Rotor pipe diameter	mm	70						
	Rotor pipe thickness	mm	8						
	Rotor work diameter	mm	385						
	Number of hoes	4 hoes/ flange		16	20	20	24	24	28
6 hoes/ flange			24	30	30	36	36	42	42
Tractor requisites	Tractor power min - max	CV	20 - 35						
	Tractor hitch category	cat	1st						
	PTO speed	rpm	540						
Sound level (no-load detection)	Acoustic pressure level	dB	87.2						
	Sound power level	dB	99.8						

5. START-UP



INJURY HAZARD!

Only qualified operators who have read and understood the safety instructions can perform the operations described below. Moreover, they must check that there are no persons, animals and properly exposed in the area where the connection is made to the tractor.

The operator and any assistants must have PPE (Personal Protection Equipment) available and use it as required.

The Tiller can only be moved and used if connected to the tractor. To connect to the tractor, assume a position on compact and flat ground and carefully follow, in the order shown, the instructions below:

- CONNECTING THE TILLER TO THE TRACTOR (3-point hitch);
- CONNECTING THE PTO DRIVE SHAFT (power take-off).

5.1 CONNECTING THE TILLER TO THE TRACTOR

To connect the Tiller to the tractor, the operator must slowly approach the tractor in reverse to the Tiller and position themselves so that the arms of the tractor lifter are aligned with the two lower pins of the Tiller.

Once in position, apply the parking brake, stop the engine, remove the ignition key and keep it on your person, then get off the tractor.

To couple the equipment to the tractor proceed as follows:

- remove the cotter "A" of the pin "B" on both sides;
- Slide the pins "B" out;
- Start the engine, release the parking brake and move back slowly until the articulation of the lifting arm of the tractor "C" is aligned with the third lower point "D" of the Tiller;
- Stop the engine, apply the parking brake, remove the key and keep it on your person;
- Insert the pin into the hole of the lower third point "D" of the Tiller and into the hole of the tractor arm joint "C";
- Re-insert the cotter pin "A";
- Do the same with the other lower connection;
- Lock the shock absorbing tie-rods of the lifting arms of the tractor to prevent the machine from swinging laterally, compromising the transverse stability of the tractor/Tiller unit.

To connect the upper third point, the operator must:

- Remove the cotter "E" of the pin "F" from the third upper point "H" of the Tiller;
- Slide pin "F" out;
- Release the tie-rod "G" of the upper third point of the tractor and insert it into the upper third point "H" of the Tiller;
- Reinsert the pin "F" and the cotter "E" both in the upper third point of the Tiller and in the joint of the tractor tie-rod;
- If you use a floating upper third point make sure that it enables the machine to tilt to the front and to the rear and that the PTO shaft is parallel to the ground;
- If the floating upper third point is not used, adjust the length of the tie-rod in a way that the PTO shaft is parallel to the ground.



It is always good practice to make sure that the tiller PTO axis is parallel to the ground thus reducing stresses to a minimum on the power take-off and extending the working life of the Tiller.

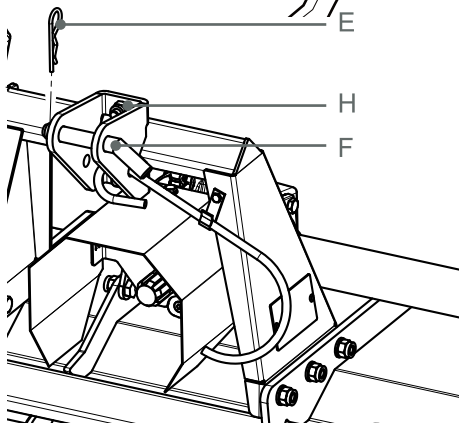
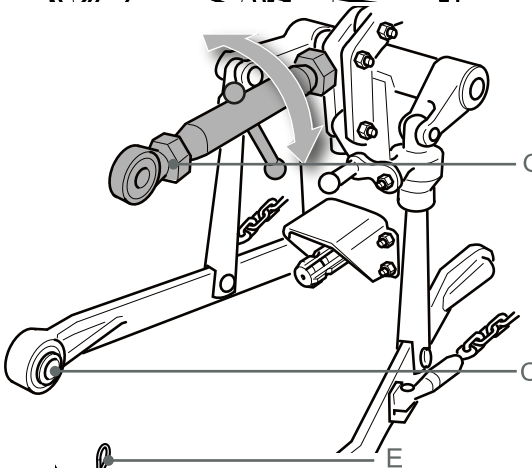
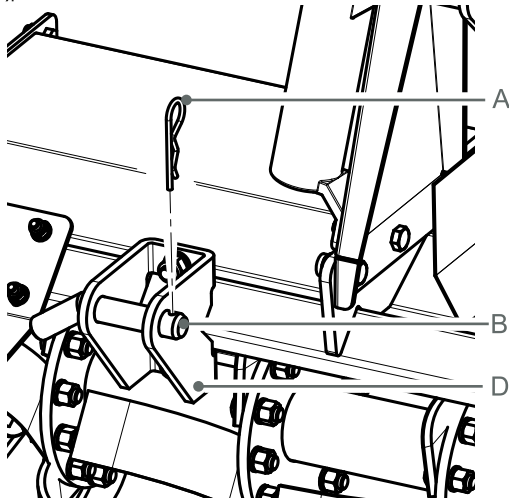
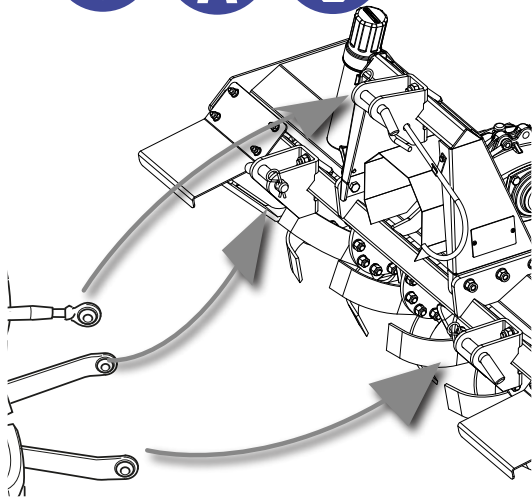



5.2 PTO DRIVE SHAFT COUPLING

Before installing the PTO drive shaft, the operator must:

- Read and understand the manual of the PTO drive shaft and of the tractor;
- Check that the number of revs. and the direction of rotation of the tractor PTO correspond to those of the Tiller. If the direction of rotation of the Tiller does not correspond to that of the tractor, contact the dealer or an authorised workshop;
- Verify that the minimum and maximum length of the PTO drive shaft are those required by the tiller-tractor coupling. Remember that when at maximum extension, the pipes must overlap at least $1/3$ of the length of the internal pipe. Moreover, in the maximum closure position of the pipes, the minimum clearance allowed of the plastic protections must be at least 2 cm. in order to prevent damage to the protections and to the gear transmission. If this is not the case, it must be shortened by cutting it as much as necessary; refer to the PTO drive shaft use and maintenance manual or contact your authorised dealer.
- Check that the PTO drive shaft protection is 100% intact, otherwise proceed accordingly by consulting the relevant user manual.

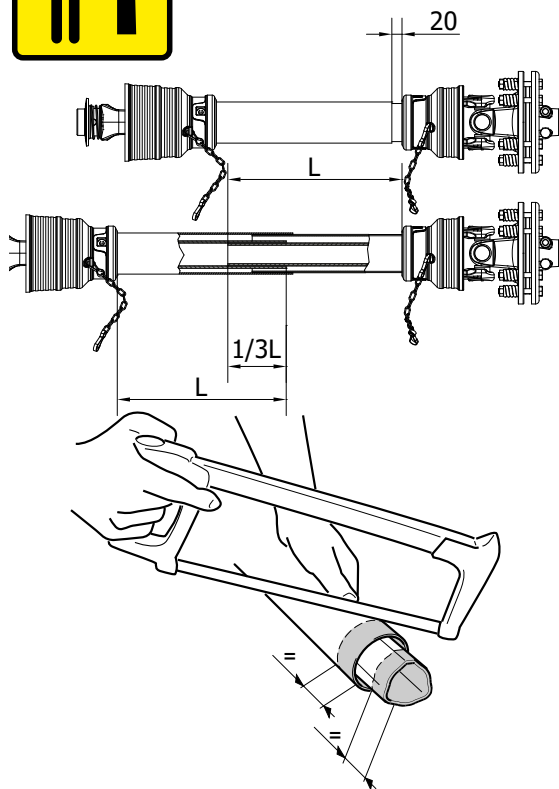

To connect the PTO drive shaft, the operator must:

- Loosen and extract the screw "A" located above the protection.
- Remove the PTO protection by pulling it upwards to disengage the lateral fixing tabs "B".
- Direct the shaft correctly, so that the clutch is positioned from the side of the equipment. In the event of joint without clutch, to position the shaft correctly, refer to the figure of the tractor embossed on the external protection pipe.
- insert the PTO drive shaft hub onto the tiller PTO, making sure that the clutch/PTO coupling is complete.
- Tighten the double bolt with two spanners.
- Insert the PTO drive shaft free hub onto the tractor PTO, holding the safety pin pressed; releasing it only when the end of travel has been reached.
- Retract the PTO drive shaft until the pin engages in its seat with an audible "click".
- Reposition the PTO protection by correctly engaging the fixing tabs "B" and tighten the screw "B".
- Then hook the snap hooks of the retaining chains of the cardan shaft protection to the tiller and tractor.

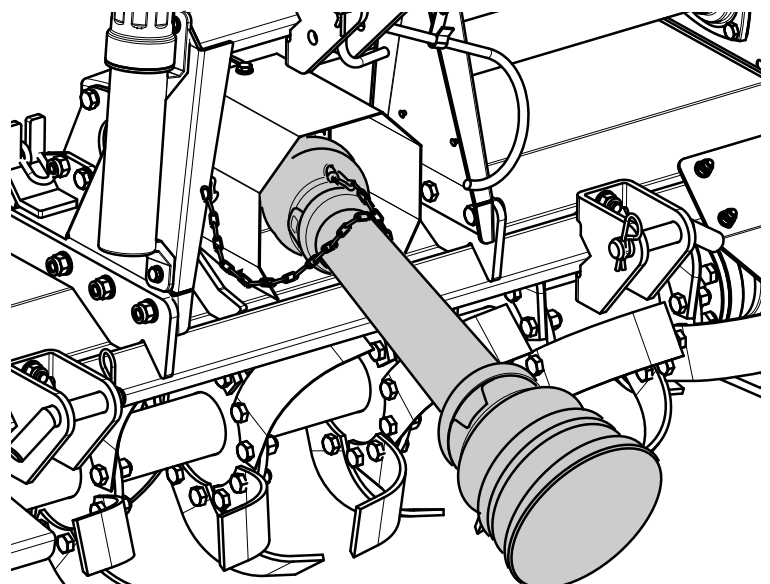
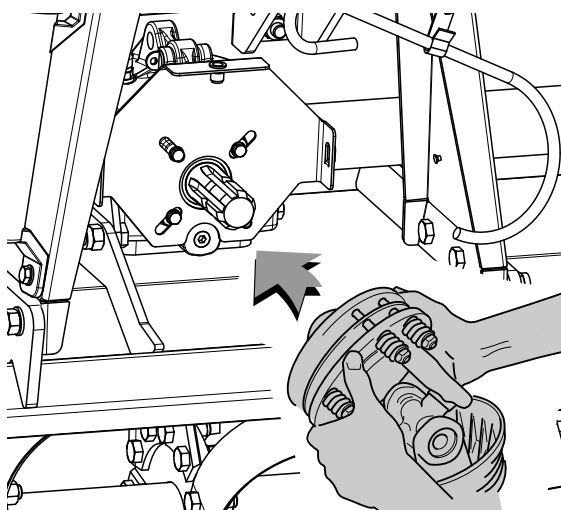
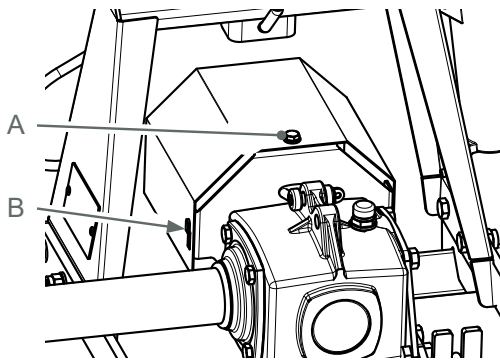

5.3 CHECK THE STABILITY OF THE TRACTOR-TILLER COMPLEX.

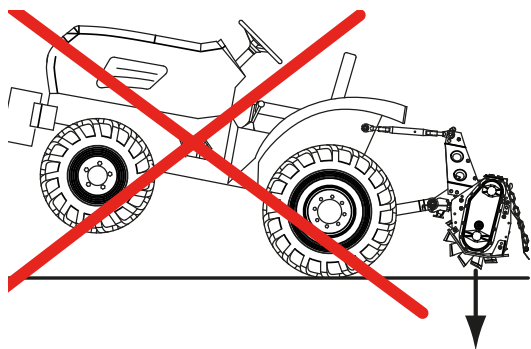

Tiller weight changes the stability of the tractor-Tiller complex, influencing steering and braking capability. Therefore proceed at a moderate speed. In particular, it should be noted that the front axle must always be carrying a load of at least 20% of the weight of the tractor-Tiller unit.

Check the lifting capacity and stability of the tractor using the following formula and, if necessary, before applying the front weights.

$$M \times (S1+S2) \leq 0.2 T \times i + Z \times (d+i)$$

$$M \leq 0.3T$$

i	= wheelbase
d	= distance between the front axis and the ballasts
S1	= distance between centre of the rear axle and centre of the lower connection points
S2	= distance between the centre of the lower hitch points and the barycentre of the tiller
T	= weight of the tractor + 75Kg (operator)
Z	= mass of the ballast
M	= the mass of the machine

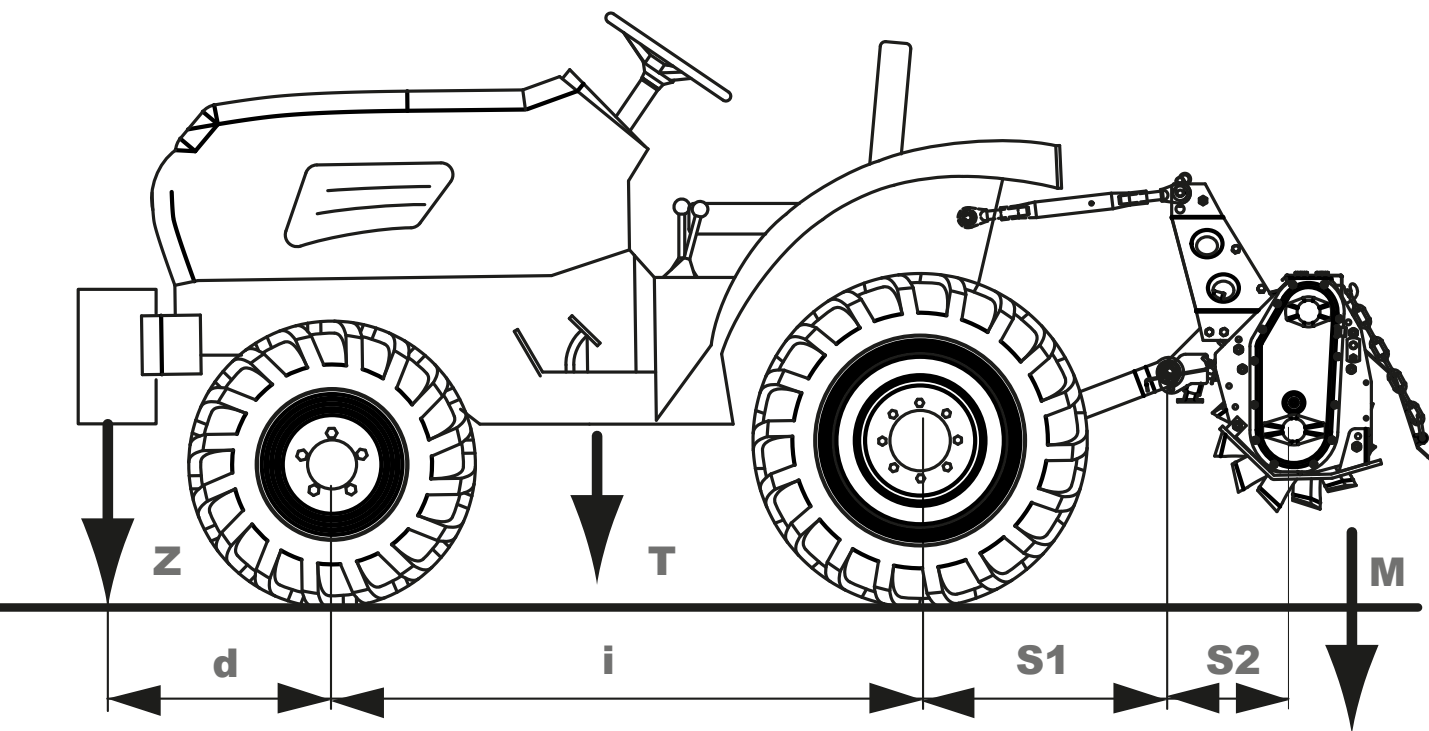

5.4 ROAD TRANSPORT

Articles 61 and 104 of the Highway Code of the Italian State prescribe that the maximum width of vehicles on roads is 2.55 metres. As a consequence, all measurements of the ZLL available are authorised for road transport, in compliance with the other prescriptions of the Highway Code.

If the Country of reference is not Italy, follow the Highway Code Standards of the country of use.

6. ADJUSTMENTS

6.1 CLUTCH ADJUSTMENT

The clutch, which is fitted on the coupling supplied with the Tiller, is sized to transmit the correct power to the equipment and is calibrated and pre-set at the factory; it is, therefore, inadvisable to modify this value in order to prevent damage to the Tiller or to the PTO drive shaft.

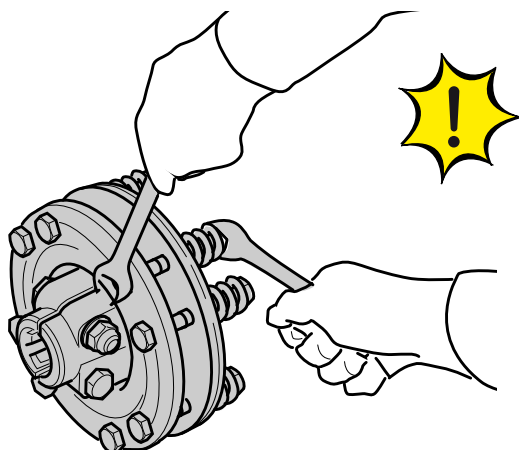

WARNING!

SICMA shall not be liable for damage deriving from incorrect modification of the clutch calibration.

However, adjustment becomes necessary if the clutch is triggered too frequently, while operating on easily machinable soils, i.e. neither hard nor compact: this means that the clutch calibration is too low.

The clutch associated to the drive shaft is an FD0 EUROCARDAN, with standard calibration of 700 Nm. If it is necessary to increase the calibration of the clutch, tighten the spring clamping nuts by 1/3 turn, thus obtaining an increase in transmissible torque by approximately 130 Nm. Unscrew the nuts if this value needs to be reduced.

If you do not plan to use the equipment for a long period, it is advisable, after noting the height of the springs measured with a precision gauge, to unscrew the nuts compressing them to prevent the discs from “sticking” to each other and causing them to seize.

When reusing the safety device, restore the original calibration by adjusting the heights of the springs as follows:

- Screw the nuts by hand until the clearances of the springs are zero;
- Screw a nut precisely counting the number of revolutions necessary to reach the original height of the compressed spring;
- Screw all the other bolts with the same number of revolutions used for the first.



CAUTION!

Ensure that the height of the compressed springs is the same for all of them to prevent clutch malfunction.



WARNING!

Do not pack the clutch springs together as the equipment would be unprotected from overloads.



6.2 WORK HEIGHT ADJUSTMENT

The working height can be modified by altering the positions of the lateral skids.

CRUSHING HAZARD!

There are 2 adjustment options for skids, as well as the holes for locking them. To modify the position of the skids, after having lifted the tiller and having positioned it on supports, proceed as follows:

- Loosen bolts “A” and “B”.
- Loosen and remove bolt “C”.
- Re-position the skid at the second adjustment, making the hole in the plate correspond with the second in the skid securing bracket.
- Re-position and tighten bolt “C”.
- Tighten bolts “A” and “B”.
- Proceed with the same procedure on the opposite skid, making sure that both are adjusted to the same height.

Finally, check that the Tiller is parallel to the ground and, if necessary, adjust its planarity by using the lever on the tie-rod of the 3rd upper point (see sec. 5.1).

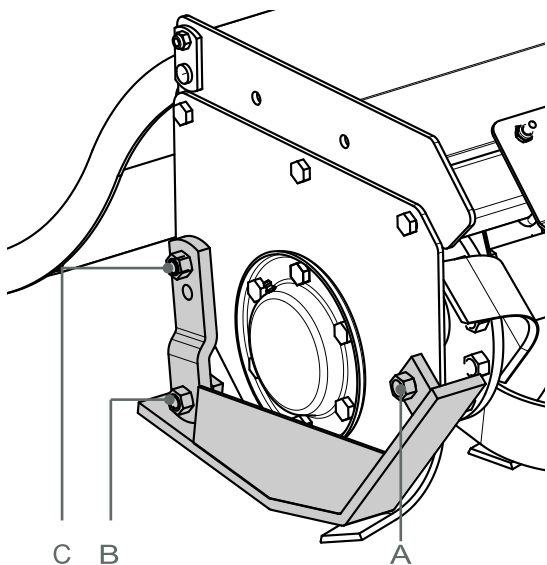

7. USE

The Tiller is interchangeable equipment (Machinery Directive art. 1 paragraph b) and to work it must be connected to a tractor; it is from the tractor itself that all its controls are managed.

The operator must refer to the tractor user's manual in order to ensure proper functioning of the Tiller.

Once all checks and adjustments have been performed, with the tractor connected to the Tiller (via the 3-point hitch with the PTO drive shaft disconnected), start the tractor and go to the working area, keeping the Tiller raised above the ground so that the blades do not touch the ground (at least 20 cm).



WARNING!

Before using the Tiller make sure that no persons or animals are within the range of action of the machine.

Make sure all equipment guards are present and efficient.

The machine must only be used by one operator positioned inside the tractor driving cab.



NOTE!

Before using the Tiller, read the following procedures, in order to be prepared in time for any situation.

Upon arrival at the work place, the operator must:

- Engage the parking brake;
- Switch the engine off;
- Remove the ignition key and keep it on themselves;
- Connect the drive shaft to the tractor PTO (section 5.2).
- Start the tractor's engine;
- Release the parking brake;
- With the Tiller raised, start the PTO, activate the descent of the Tiller and allow the rotating tools to penetrate the ground;
- Start the tractor and proceed at a maximum speed of 6 km/h;

Only the technical sensitivity of the operator, the result of his/her experience, allows to maintain the right rotation speed of the tractor engine based on the specific use.

In case of soil that is difficult to work (hard, stony, etc.), reduce the speed by approx. 2 km/h;



RECOMMENDATION!

In cold weather, it is a good idea to start the equipment at low speed to allow the Tiller to reach the right operating temperature.

Move for a short distance with the tiller working and check the quality of the work. If it does not satisfy you, repeat and review the machine adjustment operations (section 6).



LIMB INJURY HAZARD!

Never place hands and feet near to the tools-holder rotor when it is rotating (or when not in Zero Energy State).



RISK OF PERSONAL INJURY!

During operation, the machine can eject material at high speed: make sure that there are no exposed animals or persons to the rear of the Tiller.

In the operations involving sudden steering, turning and moving in reverse, disengage the power take-off and lift the tiller slightly from the ground, in order to avoid damaging its frame.

Once the work has been completed, the operator must:

- Engage the parking brake;
- Turn off the engine, remove the start key and keep it;
- Disconnect the drive shaft from the tractor PTO and position it on the dedicated support hook;
- Restart the tractor and, ensuring that there are no exposed persons or animals, move to the storage place.

Having reached the depot, the operator must:

- Engage the parking brake;
- Turn off the engine, remove the start key and keep it;
- Clean the Tiller (see chap. 9);
- Check that there are no oil leaks and, if any, fix them;
- Check the condition of the equipment and replace any worn parts (see Chap. 10).



NOTE

Should any faults arise while using the Tiller, consult section 14.2 "Troubleshooting".

8. STOPS



INJURY HAZARD TO OPERATORS AND DAMAGE TO THE STRUCTURE!

Only qualified operators that have read and fully understood the safety prescriptions (chap. 2) can perform the operations described below.

Moreover, they must check that there are no exposed people, animals and objects in the dangerous area.

The equipment must be stopped in the following ways:

- Temporary stop;
- Day end stop;
- Long downtime period;
- Emergency stop.

TEMPORARY STOP

To stop the Tiller temporarily, just deactivate the rotation of the tractor PTO by activating the control on the tractor's control console.

DAY END STOP

- Engage the parking brake;
- Turn off the engine, remove the start key and keep it;
- Clean the Tiller (see chap. 9);
- Check that there are no oil leaks and, if any, fix them;
- Check the condition of the equipment and replace any worn or damaged parts (see Chap. 10).

LONG DOWNTIME PERIODS

- Engage the parking brake;
- Adjust the outrigger of the Tiller, so as to stabilise it correctly;
- Place the Tiller on the ground;
- Engage the parking brake;
- Turn off the engine, remove the start key and keep it;
- Disconnect the drive shaft and place it on the support hook;
- Release the Tiller from the tractor using the 3-point hitch pins;
- Restart the tractor and move away carefully;
- Lubricate all Tiller parts with an anti-oxidant product.

The Tiller must be parked on a flat, compact surface within a protected area, so as to prevent access of unauthorised persons.

EMERGENCY STOP

The emergency stop procedure should be carried out in the event of a hazard or malfunction and consists of:

- Turn off the PTO to stop the Tiller and stop the tractor;
- Engage the parking brake;
- Turn off the engine, remove the start key and keep it;
- Identify the cause of the emergency stop and, if necessary, consult the “Troubleshooting” table (section 14.2).

Then decide whether:

- It is necessary to place the equipment to a Zero Energy State;
- Technical support must be called;
- It can be repaired.

Once the cause of the emergency stop has been eliminated, restart the Equipment and finish the work.

9. CLEANING



INJURY HAZARD TO OPERATORS AND DAMAGE TO THE STRUCTURE!

Only qualified operators that have read and fully understood the safety prescriptions (chap. 2) can perform the operations described below. Moreover, these must check that there are no exposed persons and animals in the dangerous area.



INJURY HAZARD!

During cleaning, use all the necessary PPE such as cut-resistant gloves and safety shoes, and be very careful not to touch the sharp parts of the hoes with bare hands.



The operator must carry out cleaning operations on a non-yielding, flat surface, only after having placed the Tiller in a Zero Energy State (section 2.3).

If using compressed air to clean the machine, protect yourself with suitable safety eyewear.

At the end of every work day, it is advisable to wash the Tiller with a pressure washer, especially the following parts:

- Chassis surface;
- Hoes;
- Mast;
- Rear hood;
- Rotor.

To clean the rotor compartment, lift the rear covers.

After washing, dry with compressed air and protect the non-coated metal parts by applying a layer of lubricant to prevent oxidation.

10. ROUTINE MAINTENANCE



INJURY HAZARD TO OPERATORS AND DAMAGE TO THE STRUCTURE!

Only qualified operators that have read and fully understood the safety prescriptions (chap. 2) can perform the operations described below. Moreover, they must check that there are no exposed persons, animals or objects in the hazardous area.

The operator must be familiar with and strictly observe the instructions described and must have placed the Tiller into a “Zero Energy State”.



WARNING!

The periodic checks and the maintenance described in this chapter should be performed at the intervals and using the methods established and are the operator's responsibility.

Failure to comply with maintenance standards and schedule compromises the

proper operation of the machine and its service life, and voids the warranty.



For all other maintenance, see sec. 14.2 ("Troubleshooting") or contact the Manufacturer or its After-sales centres.

Given the complexity of the equipment, repairs, modifications, non-routine maintenance other than those listed below must NOT take place without consulting the Manufacturer or their support centre. Depending on the circumstances, these will provide authorisation and all necessary instructions, or alternatively they will recommend an intervention by one of their own technicians.

Compliance with these precautions protects the operators and keeps the equipment intact.



OVERTURNING HAZARD!

Ensure the stability of the equipment before attempting any maintenance.



The maintenance technician and any aids must have PPE available and wear them as required.

Do not perform repairs whose outcome may be doubtful. Always follow the instructions and, if they are lacking, contact the supplier or expert personnel.



POISONING HAZARD!

Do not leave the tractor engine on inside closed spaces not equipped with ventilation system.



- Avoid prolonged and repeated skin contact with lubricants as they could cause skin disorders or other types of syndromes.
- Do not swallow fuel/lubricants/fluids. In case of accidental contact with eyes rinse thoroughly with tap water.
- Do not weld in closed places or rooms that are not appropriately ventilated.
- Do not weld painted surfaces: first remove the paint layer with suitable products, then wash and allow to dry.

10.1 CHECK AND REPLACEMENT OF OIL IN THE TRANSMISSION ASSEMBLY

usare esclusivamente use only user exclusivemnt	
olio idraulico hydraulic oil huile hydraulique	OSO 15-32-46-68
riduttore gear oil huile pour engranages	Blasia 150
lubrificazione a grasso grease lubrication	Grease MU EP 2



BURN HAZARD!

Before touching the upper transmission unit, wait until it has cooled down sufficiently.



CONTAMINATION HAZARD!

Check that there are no oil leaks and, if necessary, fix them immediately. Do not spill oil onto the ground during top-up or replacement.



WARNING!

Correctly recover the used oils and dispose of them at the appropriate collection centres, as, according to current regulations, it must not be released to the environment because it is classified as hazardous waste. It is therefore necessary to contact the "Consorzio Obbligatorio Oli Usati" (www.coou.it; green line **800-863048**). For the other countries, refer to the respective anti-pollution regulations in force.

CHECK THE OIL LEVEL
(Every 50 hours)

Check the oil level of the transmission unit by checking that the mark left by the oil itself on the dipstick of the filler cap "A" is between the two reference marks (minimum and maximum).

If it is necessary to add more oil, proceed as follows:

- Remove the oil filler cap "A".
- Top up with AGIP-ENI BLASIA 150 type oil until the level is restored as indicated above;

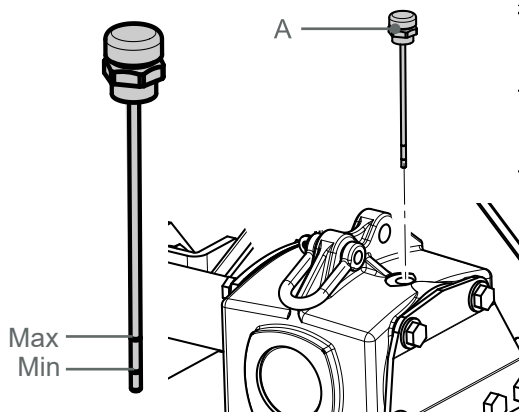

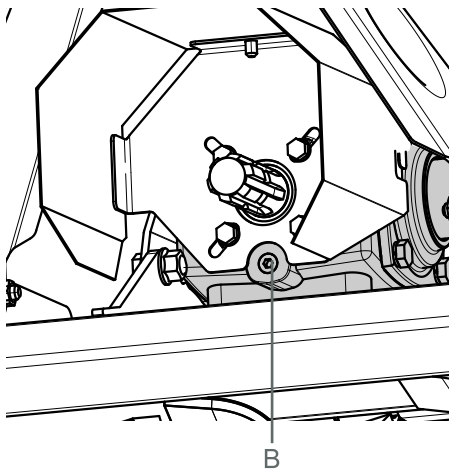

- Refit and tighten the filler cap "A".

OIL REPLACEMENT

(The first time after the first 50 hours and then every 500 hours)

To replace the oil, proceed as follows:

- Unscrew the filler/vent cap "A".
- Place a sufficiently large container under the drain cap "B" (approximately 2 litres).
- Remove the cap "B" and wait for the used oil to drain completely inside the tray.
- Reposition and tighten the drain cap "B".
- Top up with ENI BLASIA 150 type oil until the correct level is restored (approximately 0.75 litres).
- Replace and tighten the drain cap "A".
- Dispose of the drained oil in appropriate containers for waste oils.

10.2 CONTROL AND REPLACEMENT OF THE OIL IN THE LATERAL DRIVE SUMP

CHECK THE OIL LEVEL

(Every 50 hours)

Check the oil level in the lateral transmission casing by checking that it is visible inside the window of the cap "C".

If it is necessary, top up with the following steps:

- Unscrew and extract the oil filler cap "D".
- Top up with AGIP-ENI BLASIA 150 type oil until it becomes visible from the window of the cap "D".
- Replace and tighten the filler cap "D".

OIL REPLACEMENT

(The first time after the first 50 hours and then every 500 hours)

To change the oil, proceed as follows:

- Loosen the oil filler cap D.
- Suction the used oil from the hole in cap "D" with a dedicated pump.
- Top up AGIP-ENI BLASIA 150 type oil from the hole in cap "D" until it becomes visible inside the window of cap "C" (approximately 1.3 litres).
- Tighten the filler cap D well.

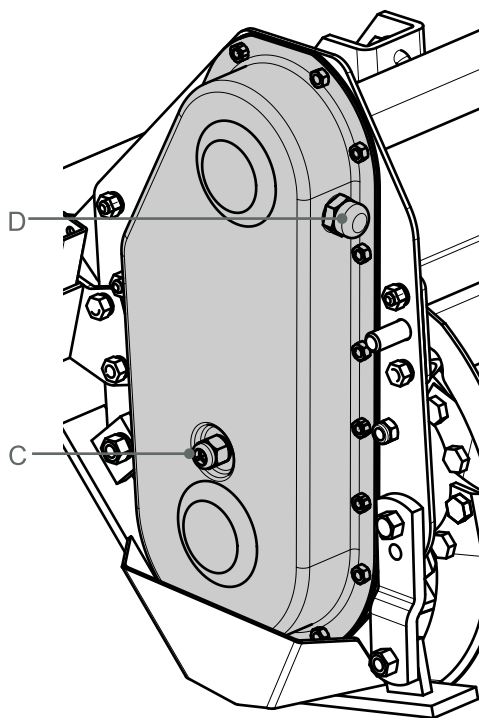

CONTAMINATION HAZARD!

Check that there are no oil leaks and, if necessary, fix them immediately. Do not spill oil onto the ground during top-up or replacement.



WARNING!

Correctly recover the used oils and dispose of them at the appropriate collection centres, as, according to current regulations, it must not be released to the environment because it is classified as hazardous waste. It is therefore necessary to contact the "Consorzio Obbligatorio Oli Usati" (www.coou.it; green line 800-863048). For the other countries, refer to the relative anti-pollution regulations in force.



Oli Usati" (www.coou.it; green line 800-863048). For the other countries, refer to the relative anti-pollution regulations in force.

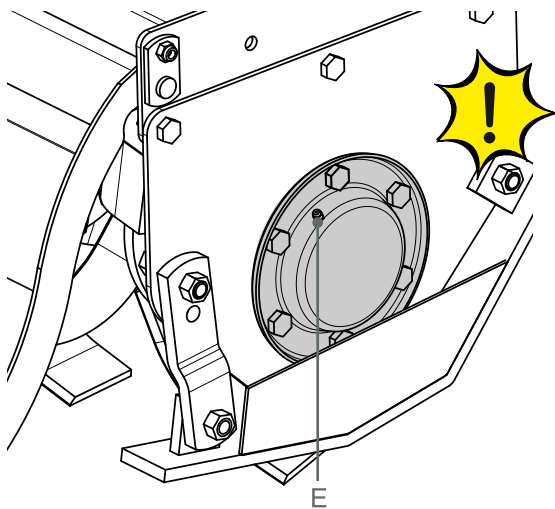

10.3 GREASING

WARNING!

Before injecting lubricating grease, carefully clean the grease nipples to prevent dust or impurities of any kind from mixing with the grease, reducing lubrication efficiency.

For greasing, use a special pump for HYDRAULIC greasers type "A" UNI 7663 and **AGIP GREASE MU EP 2** grease.

GREASING THE ROTOR LATERAL SUPPORT (Every 8 hours)

The greasing point of the rotor support must be greased by injecting it at the grease nipple "E" located on the right side plate.



10.4 HOE REPLACEMENT

Before carrying out the following operations, put on the necessary PPE, especially protective gloves and safety shoes.

CRUSHING HAZARD!

When you replace the tools, NEVER STAND BELOW the rotor with the Tiller raised above the ground; never rely only on the tractor's hydraulic lift tightness: insert mechanical struts or stands between the Tiller and the ground in order to avoid accidental and dangerous lowering of the machine.

VISUAL CHECK OF THE HOES (Every 50 hours)

Visually inspect the wear of the hoe blades: they should be replaced when an increase in power consumption of the tractor due to wear is detected during operation, or when blade size is significantly reduced compared to its initial size.

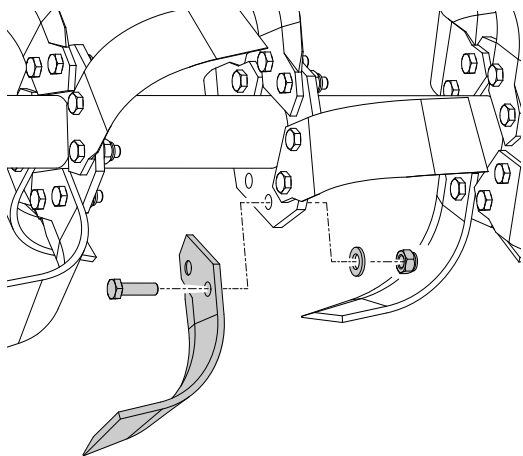

WARNING!

The Tiller is subject to heavy mechanical stress. Therefore, only the use of original tools guarantees prolonged life of the machine and the utmost safety of the operators.

The use of non-original spare parts exempts SICMA from any responsibility for damage or injuries to operators, third parties and property and causes immediate forfeiture of the warranty.

To purchase original spare parts, see the spare parts section at the web address: www.sicma.it.

REPLACING INDIVIDUAL WORN HOES (When hoe blades are worn out)

To replace a single hoe blade, proceed as follows:

- Hitch the Tiller to the tractor without the PTO drive shaft;
- Lift the Tiller;
- Stake the Tiller with supports of adequate size and turn off the engine;
- Unscrew and remove the bolts that lock the hoe to be replaced;
- Position the new hoe observing the original position and reinsert the two bolts previously extracted by repositioning screws, washers and nuts also in their original positions;
- Tighten all the flange bolts, respecting the tightening torque shown in the table in section 14.1.

REPLACING ALL HOES

(When hoe blades are worn out)

To replace all hoe blades, proceed as follows:

- Prop up the Tiller as described above;
- Replace one hoe at a time on one of the two end flanges as described in the previous section, replacing all parts (screws, hoe, washers and nuts) in their original positions;
- Once all the hoe blades of the first flange have been replaced, move to the next one and repeat the operations.

Tighten the bolts, observing the tightening torques in the table in section 14.1.

• PM14 • PM57 • PM80E



11. PTO DRIVE SHAFT

For both maintenance and any repairs, proceed as described in the use and maintenance manual by the manufacturer of the installed PTO drive shaft.

12. STORAGE AND WINTERING

If the machine is immobilised for long periods, it must be stored indoors protected from atmospheric agents, if possible, and placed on a flat, compact surface. Before setting it aside, clean the whole machine and lubricate all mechanical parts to protect them from corrosion.

Before putting the machine in long downtime periods, it is advisable to proceed as follows:

- Free the rotor and the tools from tilling residues;
- Thoroughly clean the machine;
- Perform a general visual inspection of the machine to detect any structural damage;
- Check that the original safety pictograms are present in their positions and that they are intact and legible (sec. 2.10);
- Grease all mechanical parts and the fastening pins;



RECOMMENDATION!

If the machine is fitted with a disc clutch device, it is advisable, after noting the height of the compressed springs, to unscrew the screws compressing the springs to prevent the discs from sticking to each other (see sec. 6.1).



13. SCRAPPING

In the event of scrapping, the machine must be disposed of in suitable waste disposal sites, in compliance with the law in force.

Before scrapping, separate the plastic or rubber parts. Recover any waste oils and dispose of them at relevant collection centres.

Used oil must be appropriately recovered and must not be dispersed in the environment because according to current regulations it is classified as hazardous waste and as such should be taken to the appropriate collection centres. For the collection of the used oils, it is mandatory to contact the "Consorzio Obbligatorio Oli Usati" (www.coou.it; green line 800-863048). Parts consisting solely of plastic material, aluminium, steel, can be recycled if collected by the centres.



14. QUICK CONSULTATION TABLES

The following pages, state the conditions and hypothesis of intervention for each of the cases stated above, in table form.

TIGHTENING TORQUES				
bolt class				
Threading	8.8		10.9	
	Nm	Lb-ft	Nm	Lb-ft
M6	11	8.5	17	12
M8	28	20	40	30
M10	55	40	80	60
M12	95	70	140	105
M14	150	110	225	165
M16	240	175	305	225
M18	330	250	475	350

14.1 TABLE OF TIGHTENING TORQUES

Check the condition and the efficiency of all screws and bolts every day. If necessary, replace them immediately by requesting them from the manufacturer. Replace them in the exact original position (screw, washer, nut), observing the tightening torques given in the table next to them.

14.2 TROUBLESHOOTING



NOTE!

Follow the suggestions below one at a time, starting from the most basic ones and check if the fail was fixed by attempting to use the equipment. If the faults persist despite all the remedies put in place, contact the manufacturer's technical support centre.

FAULT	CAUSE	REMEDY
Oil leakage from bevel gearbox or side transmission casing	<ul style="list-style-type: none"> • Too much oil in the box or lateral sump • Breather plug with faulty valve • Top-up/drain/level caps loose • Damaged gaskets 	<ul style="list-style-type: none"> • Restore the proper oil level • Replace the breathing cap • Tighten the top-up/drain/level caps • Replace the gaskets
Uneven ground tilling	<ul style="list-style-type: none"> • Tools worn or damaged • Machine badly adjusted (aligned skids) • Machine clogged 	<ul style="list-style-type: none"> • Replace the tools • Carry out adjustments • Decrease tractor advancement speed • Clean the tilling chamber
Overheating of the conical couple unit	<ul style="list-style-type: none"> • Insufficient oil • Soil difficult to work 	<ul style="list-style-type: none"> • Restore oil level • Reduce advancement speed
Premature tool wear	<ul style="list-style-type: none"> • Sandy or muddy ground 	<ul style="list-style-type: none"> • Reduce advancement speed
Tools breakage	<ul style="list-style-type: none"> • Stony ground 	<ul style="list-style-type: none"> • Reduce advancement speed
Excessive power consumption	<ul style="list-style-type: none"> • Volume of land worked too high • Excessive work depth • Tilling chamber clogging (damp land) • High travel speed 	<ul style="list-style-type: none"> • Decrease working depth by regulating skid heights • Lift the rear cover to facilitate the escape of earth • Decrease advancement speed

14.3 LUBRICATION INTERVALS

RECOMMENDED LUBRICANTS	
OIL	AGIP-ENI BLASIA 150
GREASE	AGIP GREASE MU EP 2

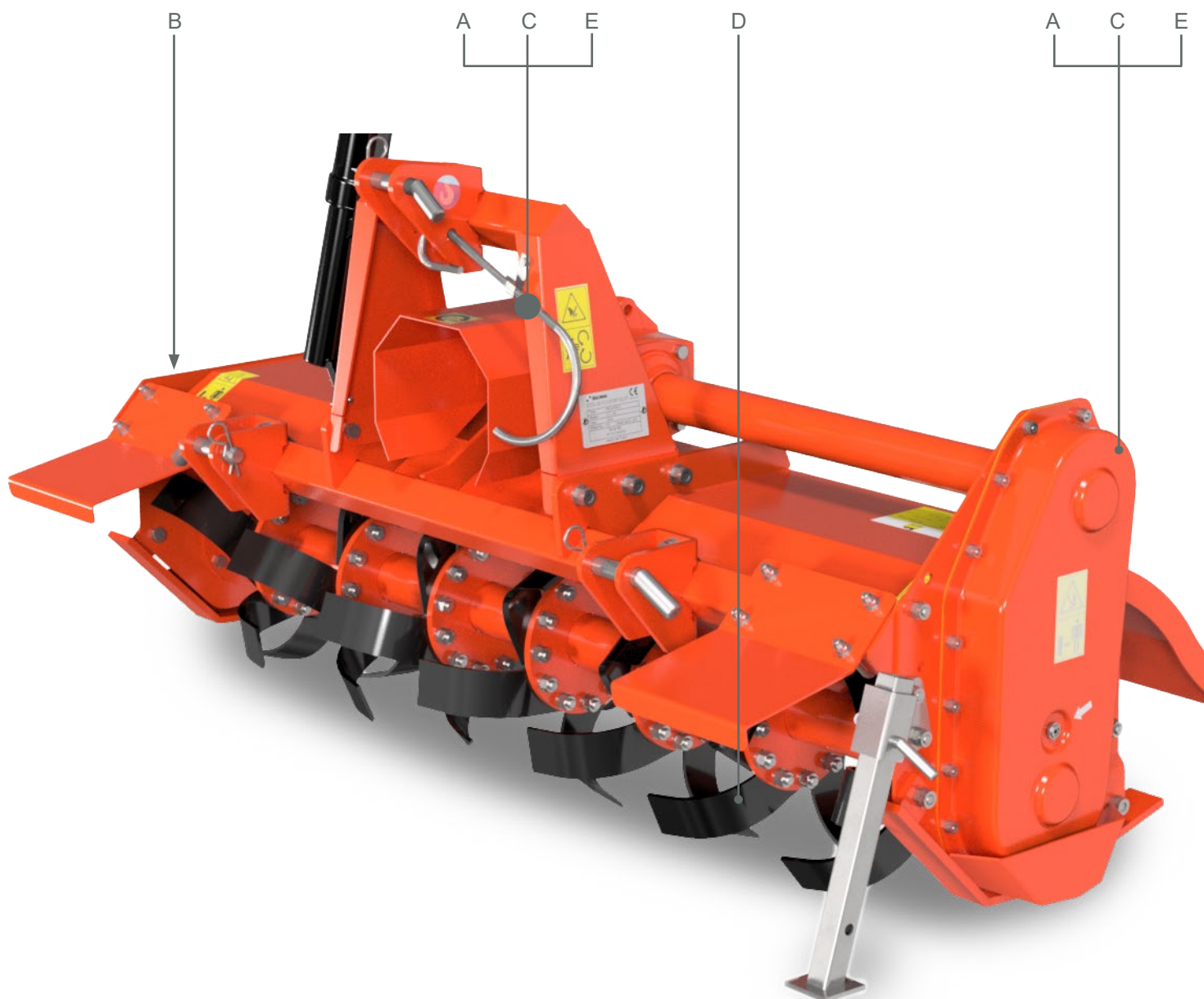

Ref.	INTERVAL IN HOURS	DESCRIPTION OF THE INTERVENTION
A	AFTER THE FIRST 50 WORKING HOURS	<ul style="list-style-type: none"> Replacing the bevel transmission assembly oil Replacing the lateral casing oil
B	EVERY 8 WORKING HOURS	<ul style="list-style-type: none"> Grease the rotor lateral support
C	EVERY 50 WORKING HOURS	<ul style="list-style-type: none"> Check the oil level in the bevel gearbox transmission and top up if necessary Check the oil level in the side casing and top up if necessary
D	EVERY 50 WORKING HOURS	<ul style="list-style-type: none"> Visually check the state of wear of the hoes and replace any damaged hoes or all, if required
E	EVERY 500 WORKING HOURS	<ul style="list-style-type: none"> Replacing the bevel transmission assembly oil Replacing the lateral casing oil

15. SPARE PARTS

Repairs and replacements of damaged or worn parts must be carried out using original parts, which must be requested from the Dealer or purchased via the website www.sicma.it. Please note that a request for spare parts must be accompanied by the following information:

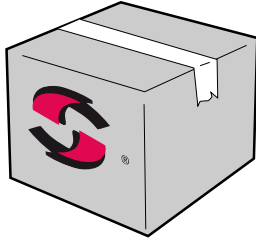

- Machine Type;
- Serial number;
- Code and description of the spare part required which can be obtained from the Exploded View of Spare Parts (www.sicma.it);
- Requested quantity.

Given the particular stress to which the equipment is subjected and for safety reasons, use exclusively original spare parts.



WARNING!

The use of non-original spare parts exempts SICMA from any responsibility for damage or injuries caused to operators, third parties and property and causes immediate forfeiture of the warranty.

16. WARRANTY

To benefit from the contractual warranty provided by the Manufacture, the operator must strictly comply with the instructions provided in the Use and Maintenance Manual, and in particular:

- Respect the limits for use set forth by the Manufacturer;
- Must not make any changes or modifications to the machine without the written approval of the Manufacturer;
- Do not bypass the safety guards;
- Always carry out all the required maintenance operations observing intervals and methods;
- Must only use original spare parts;
- Ensure that the personnel assigned to use the vehicle and equipment meet the necessary skill and training requirements.





SICMA S.p.A.
Contrada Cerreto, 39
66010 MIGLIANICO (CH) - ITALY
Tel. +39 087195841 - fax +39 0871950295